

91164



NEW ZEALAND QUALIFICATIONS AUTHORITY  
 MANA TOHU MĀTAURANGA O AOTEAROA

QUALIFY FOR THE FUTURE WORLD  
 KIA NOHO TAKATŪ KI TŌ ĀMUA AO!

2

SUPERVISOR'S USE ONLY

## Level 2 Chemistry, 2015

### 91164 Demonstrate understanding of bonding, structure, properties and energy changes

9.30 a.m. Monday 23 November 2015  
 Credits: Five

Achievement	Achievement with Merit	Achievement with Excellence
Demonstrate understanding of bonding, structure, properties and energy changes.	Demonstrate in-depth understanding of bonding, structure, properties and energy changes.	Demonstrate comprehensive understanding of bonding, structure, properties and energy changes.

Check that the National Student Number (NSN) on your admission slip is the same as the number at the top of this page.

**You should attempt ALL the questions in this booklet.**

A periodic table is provided on the Resource Sheet L2-CHEMR.

If you need more room for any answer, use the extra space provided at the back of this booklet and clearly number the question.

Check that this booklet has pages 2–12 in the correct order and that none of these pages is blank.

**YOU MUST HAND THIS BOOKLET TO THE SUPERVISOR AT THE END OF THE EXAMINATION.**

TOTAL

ASSESSOR'S USE ONLY

**QUESTION ONE**

(a) Draw the Lewis structure (electron dot diagram) for each of the following molecules.

Molecule	O <sub>2</sub>	OCl <sub>2</sub>	CH <sub>2</sub> O
Lewis structure			

(b) Carbon atoms can bond with different atoms to form many different compounds.

The following table shows the Lewis structure for two molecules containing carbon as the central atom, CCl<sub>4</sub> and COCl<sub>2</sub>. These molecules have different bond angles and shapes.

Molecule	CCl <sub>4</sub>	COCl <sub>2</sub>
Lewis structure	<pre>       :Cl:           :Cl-C-Cl:               :Cl:           </pre>	<pre>       :O:            :Cl-C-Cl:           </pre>

Evaluate the Lewis structure of each molecule to determine why they have different bond angles and shapes.

In your answer, you should include:

- the approximate bond angle in each molecule
- the shape of each molecule
- factors that determine the shape and bond angle for each molecule.

---

---

---

---

---

---

---

---

---

---

---

---

---

---

---

---

---

---

---

---

---

- (c)  $\text{BeCl}_2$  and  $\text{BF}_3$  are unusual molecules because there are not enough electrons for the central atoms, Be and B, to have a full valence shell. Their Lewis structures are shown below.

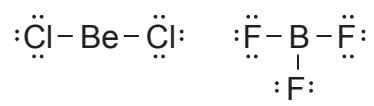

Both molecules have the same polarity.

Circle the word that describes the polarity of these molecules.

**polar**

**non-polar**

Justify your choice.

- (d) Ethene gas,  $\text{C}_2\text{H}_4(\text{g})$ , reacts with bromine gas,  $\text{Br}_2(\text{g})$ , as shown in the equation below.

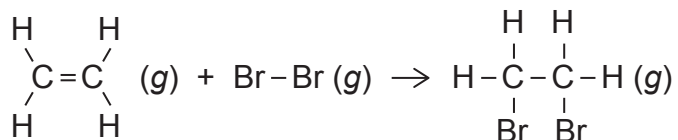

Calculate the enthalpy change,  $\Delta_r H^\circ$ , for the reaction between ethene and bromine gases, given the average bond enthalpies in the table below.

Show your working and include appropriate units in your answer.

Bond	Average bond enthalpy/ $\text{kJ mol}^{-1}$
Br-Br	193
C-C	346
C=C	614
C-Br	285
C-H	414

---

---

---

---

---

---

---

---

---

---

---

---

---

---

---

---

---

---

---

---

---

---

---

---

---

**QUESTION TWO**

- (a) Hand warmers contain a supersaturated solution of sodium ethanoate which, when activated, crystallises and releases heat.

Circle the term that best describes this reaction.

**exothermic**

**endothermic**

Give a reason for your choice.

---



---

- (b) (i) Glucose is made in plants during photosynthesis when carbon dioxide gas,  $\text{CO}_2(\text{g})$ , and water,  $\text{H}_2\text{O}(\ell)$ , react to produce glucose,  $\text{C}_6\text{H}_{12}\text{O}_6(\text{aq})$ , and oxygen gas,  $\text{O}_2(\text{g})$ . The photosynthesis reaction can be represented by the following equation:

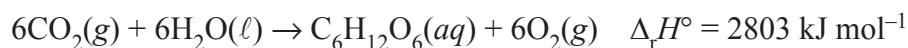

Circle the term that best describes this reaction.

**exothermic**

**endothermic**

Give a reason for your choice.

---



---

- (ii) Calculate how much energy is absorbed or released in the photosynthesis reaction if 19.8 g of carbon dioxide gas,  $\text{CO}_2(\text{g})$ , reacts completely with excess water,  $\text{H}_2\text{O}(\ell)$ , to form glucose,  $\text{C}_6\text{H}_{12}\text{O}_6(\text{aq})$ , and oxygen gas,  $\text{O}_2(\text{g})$ .

Show your working and include appropriate units in your answer.

$$M(\text{CO}_2) = 44.0 \text{ g mol}^{-1}$$

---



---



---



---



---



---

- (c) A small camp stove containing butane gas,  $C_4H_{10}(g)$ , is used to heat some water, as shown in the diagram below. A student measures the temperature change in the water and calculates that when 3.65 g of butane is combusted, 106 kJ of heat is released.

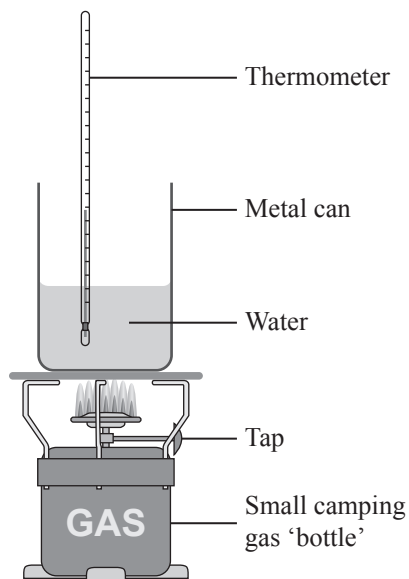

The reaction for the combustion of butane is shown in the equation below.

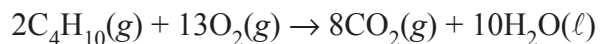

- (i) Calculate the enthalpy change ( $\Delta_r H$ ) for this reaction, based on the above measurements.

$$M(C_4H_{10}) = 58.0 \text{ g mol}^{-1}$$

---

---

---

---

---

---

---

---

- (ii) The accepted enthalpy change for the combustion reaction of butane gas,  $C_4H_{10}(g)$ , is  $\Delta_c H = -5754 \text{ kJ mol}^{-1}$ .

Explain why the result you calculated in part (c)(i) is different to the accepted value.

In your answer, you should include at least TWO reasons.

---

---

---

---

---

---

---

---

---

---

---

---

---

---

---

---

---

- (iii) Complete, including labels, the energy diagram for the combustion of butane gas showing reactants, products, and the change in enthalpy.

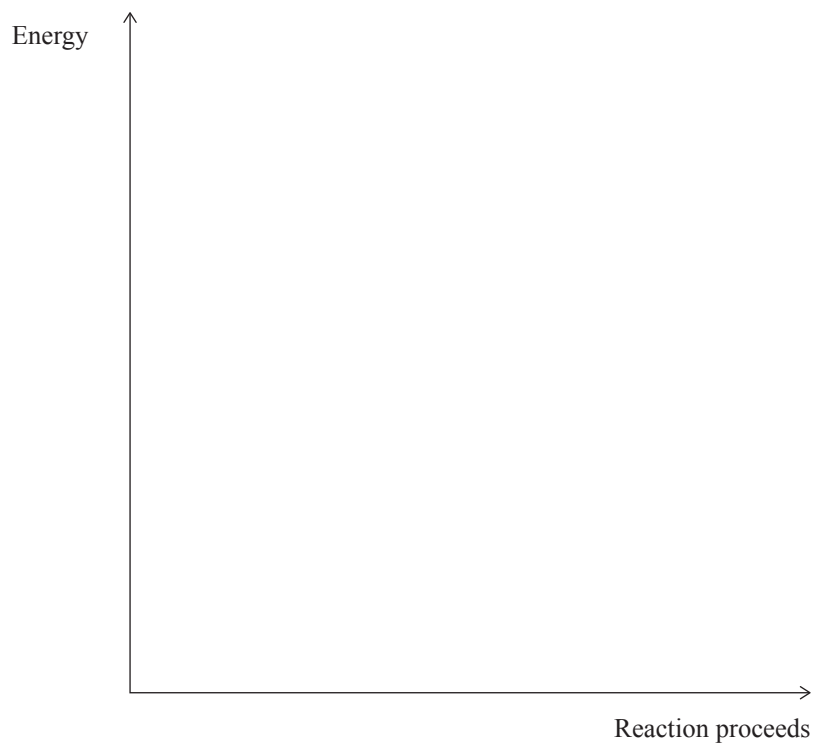

(iv) Butane gas is a useful fuel because when it undergoes combustion, energy is released.

Explain why energy is released in this reaction, in terms of making and breaking bonds.

*No calculations are required.*

---

---

---

---

---

---

---

---

---

---

---

---

---

---

--



## QUESTION THREE

- (a) Complete the table below by stating the type of solid, the type of particle, and the attractive forces between the particles in each solid.

Solid	Type of solid	Type of particle	Attractive forces between particles
$\text{Cu}(s)$ (copper)			
$\text{PCl}_3(s)$ (phosphorus trichloride)			
$\text{SiO}_2(s)$ (silicon dioxide)			
$\text{KCl}(s)$ (potassium chloride)			

- (b) Phosphorus trichloride,  $\text{PCl}_3$ , is a liquid at room temperature, and does not conduct electricity. Explain these two observations in terms of the particles, structure, and bonding of  $\text{PCl}_3$ .

---

---

---

---

---

---

---

---

---

---

---

---

---

---

---

---

---

---

---

---

---

---

---

---



**Extra paper if required.  
Write the question number(s) if applicable.**

QUESTION  
NUMBER

ASSESSOR'S  
USE ONLY

Extra paper if required.  
Write the question number(s) if applicable.

ASSESSOR'S  
USE ONLY

QUESTION  
NUMBER

91164