

No part of the candidate's evidence in this exemplar material may be presented in an external assessment for the purpose of gaining an NZQA qualification or award.



Mana Tohu Mātauranga o Aotearoa
New Zealand Qualifications Authority

Level 3 Design and Visual Communication 2025

91627 Initiate design ideas through exploration

EXEMPLAR

Merit

EXPLORATION

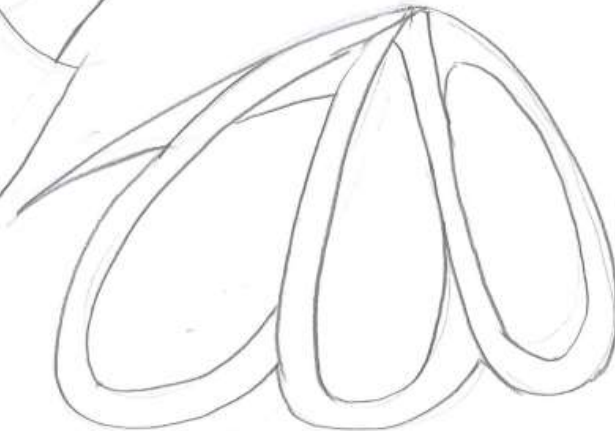
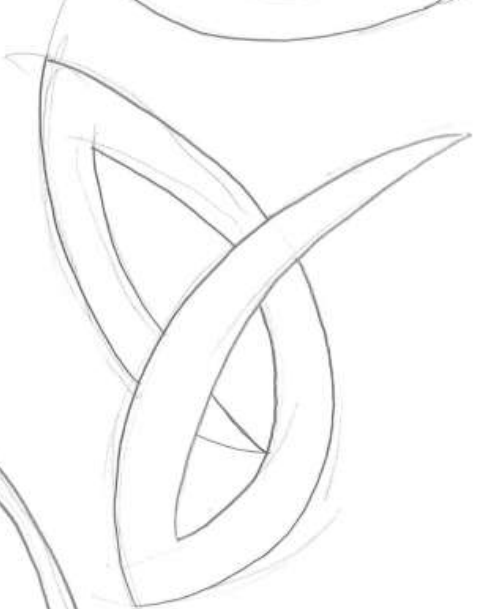
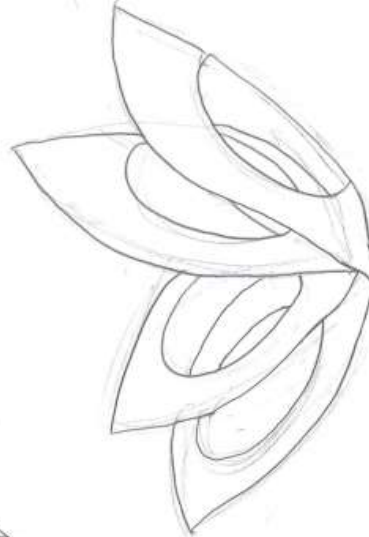
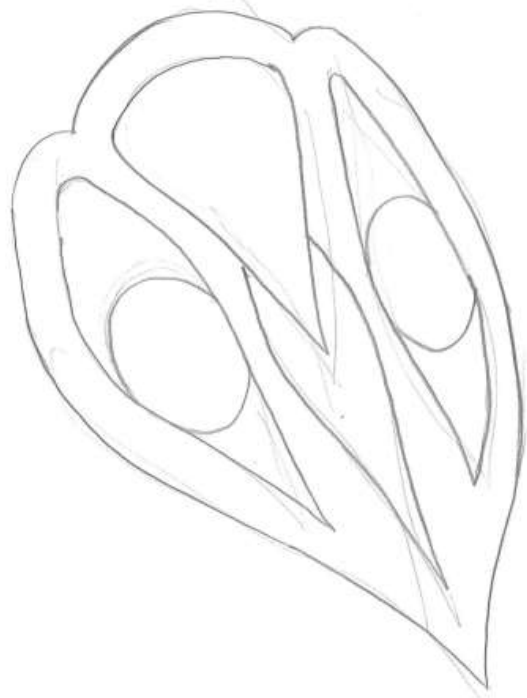
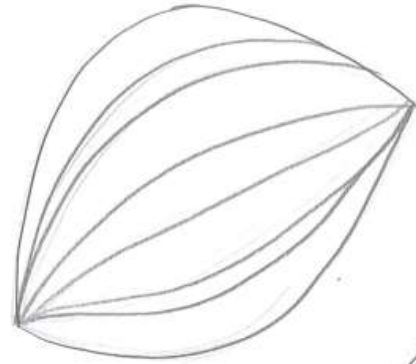

EXPLORATION

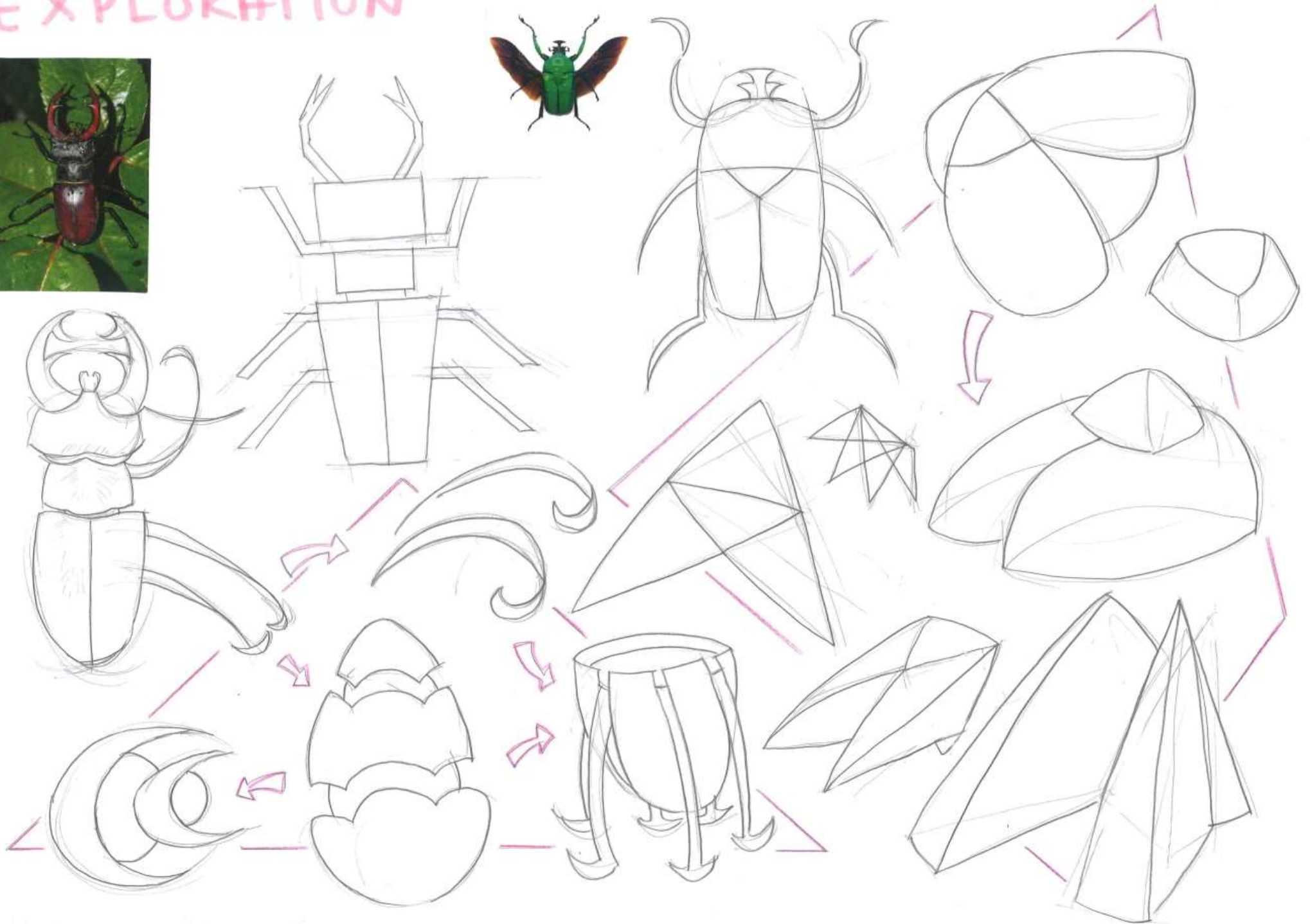

EXPLORATION

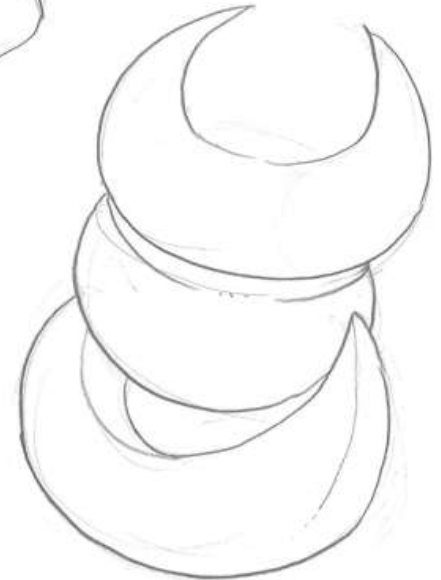
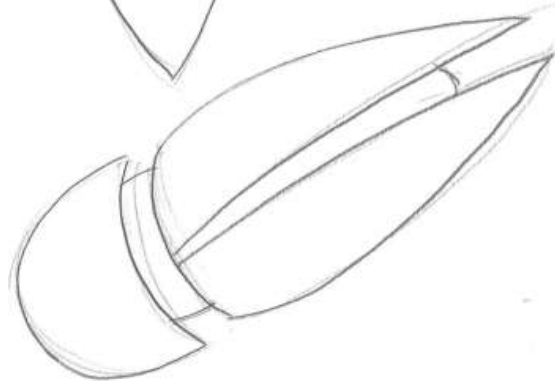
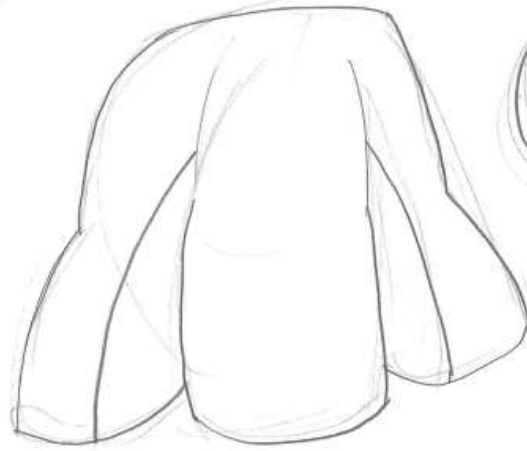
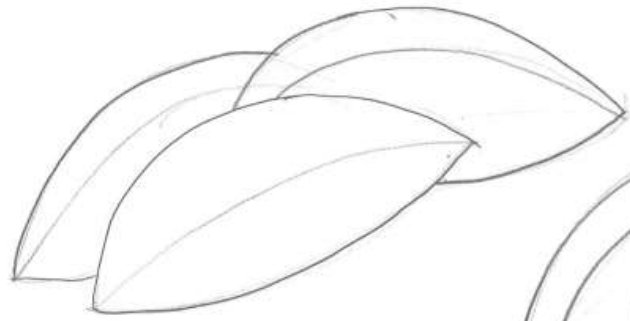
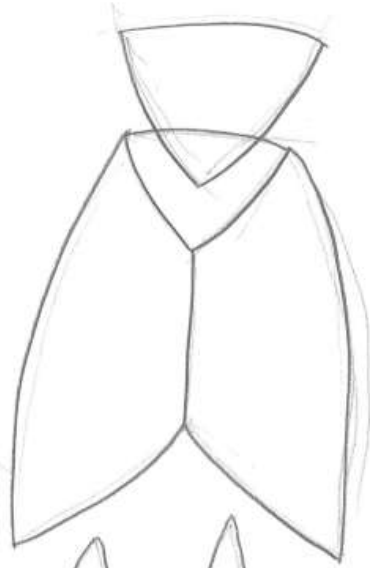
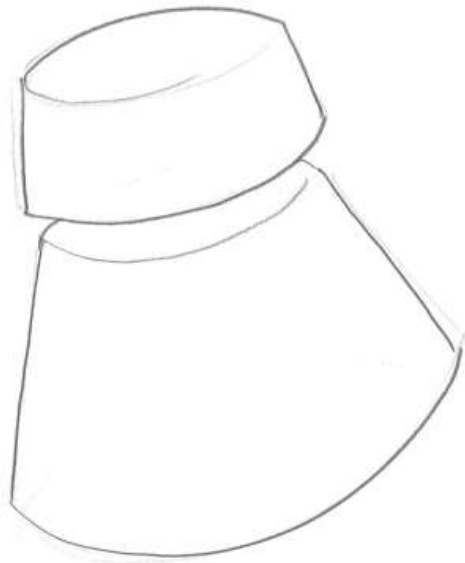

EXPLORATION

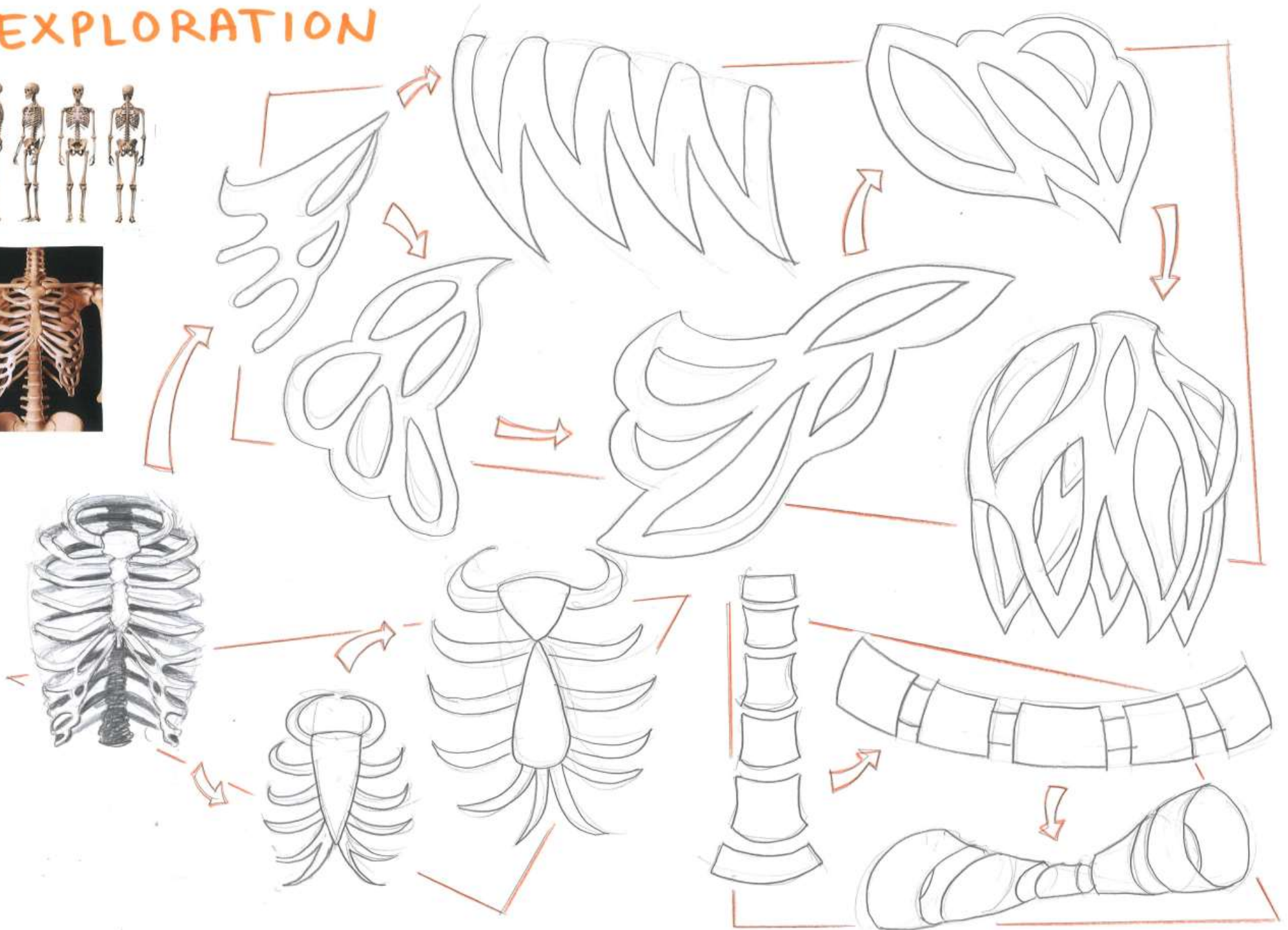

EXPLORATION

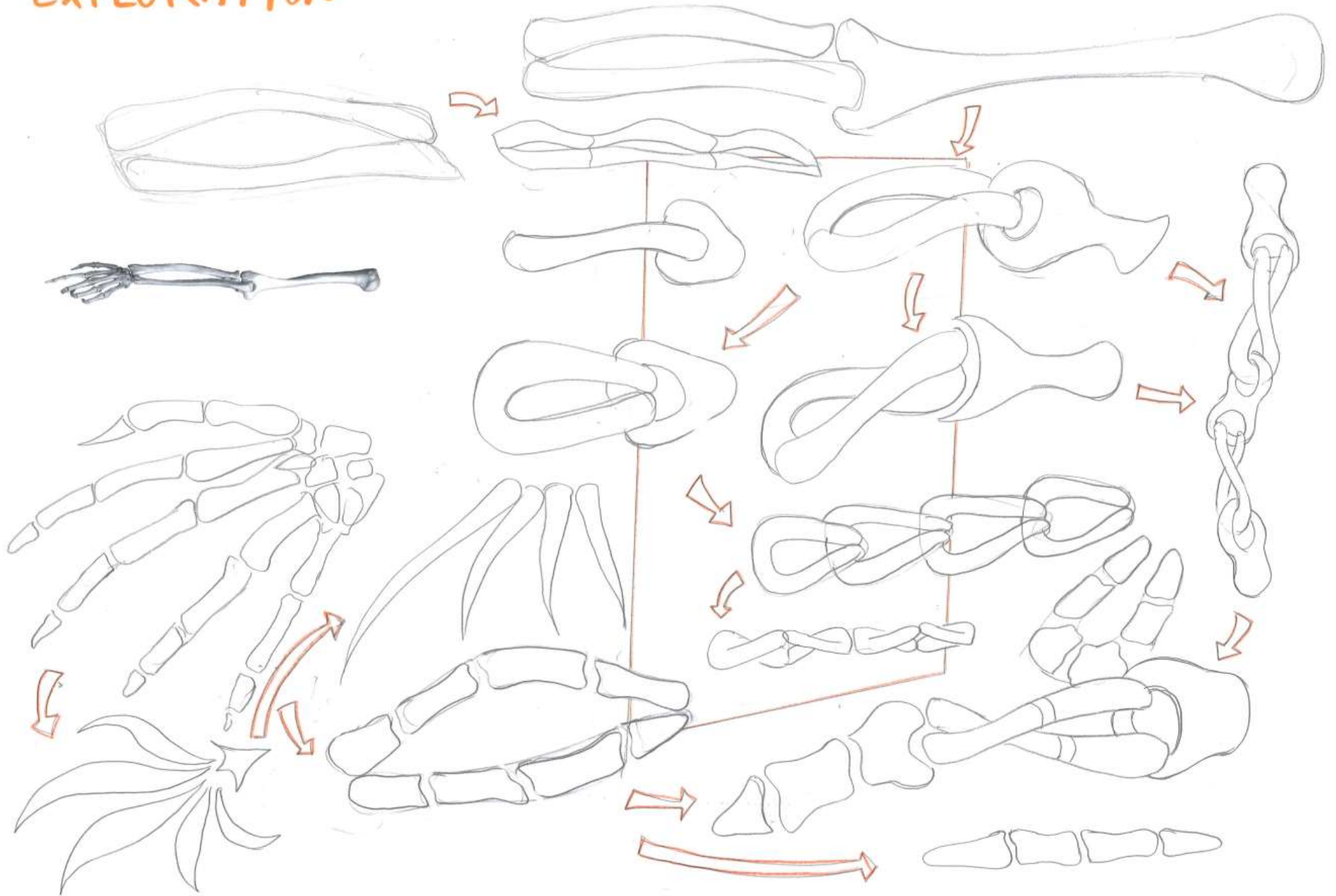

EXPLORATION

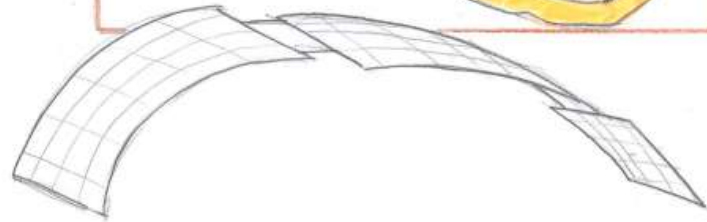
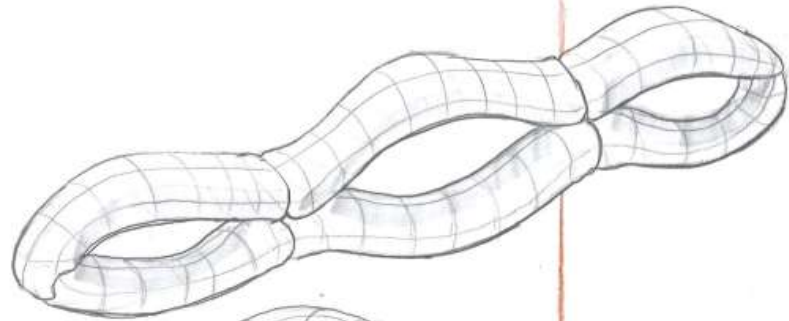
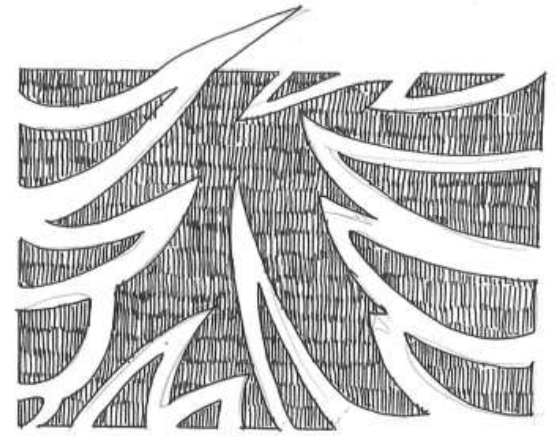
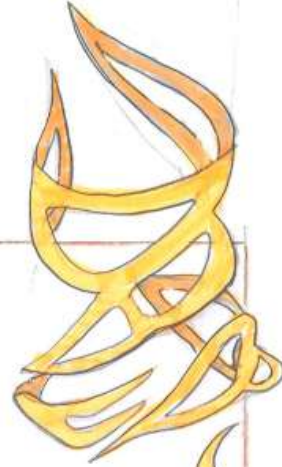
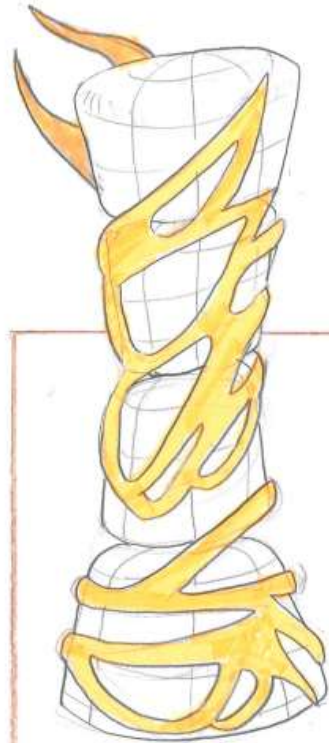

EXPLORATION

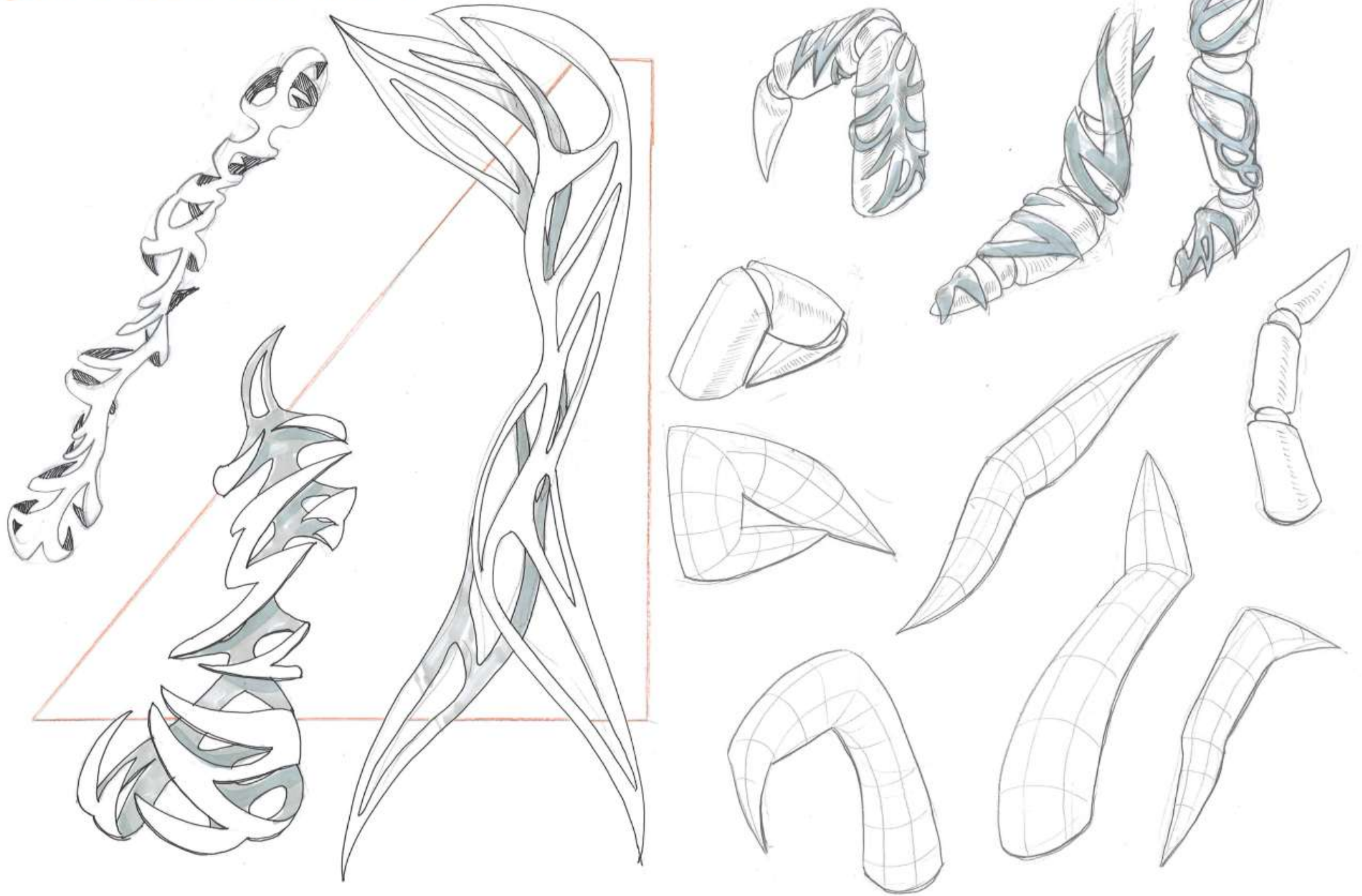

SITE ANALYSIS

BACKGROUND

John Jameson Lookout was completed in 2023, marking the Summit Road Society's 75th anniversary. This area is located within a continuous path from Godley Head, Gebbies Pass, and onto Akaroa; with the first Rest House being the Sign of the Bellbird (found just across the road from the lookout).

This place is often used to hike, walk dogs, bike, and most obviously to take in the sights.

CONSTRAINTS

Wind

- Open area, more exposed to wind

Ground is sloped

- About 11 degrees angle

Can't be obstructive

- Don't block view from platform/carpark
- Don't obstruct users movement, or inconvenience

24/7 Access

- Risk of vandalism
- Damage from public

No water plumbing

OPPORTUNITIES

- Sun visibility, and exposure
- Dark skies area

- VIEWS/AREA:

BRIEF

I am going to design a seating and drinking fountain for the users of the John Jameson Lookout- It's purpose is to be a place of rest and regeneration.

SPECIFICATIONS

- Easily accessible for users of the John Jameson Lookout
- Use ergonomic data to be suitable for users of the John Jameson Lookout
- Must be wheelchair accessible
- Does not obstruct the flow of movement, or any activities within the site
- Use material that is appropriate and suitable for the environment of the site
- Integrate aspects of my explored inspirations
- Have a piping system

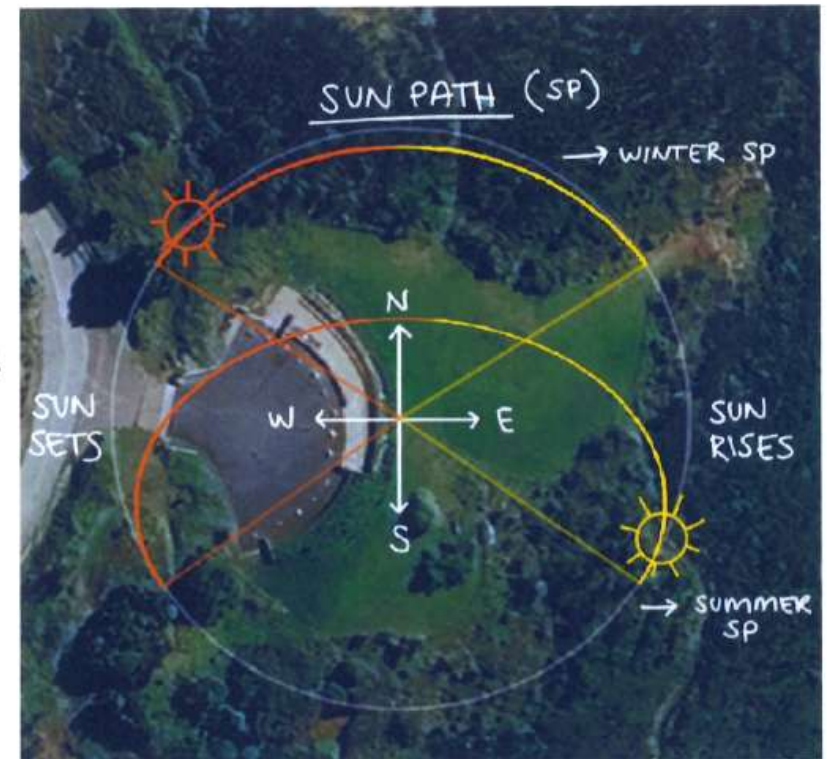

SITE ANALYSIS

POTENTIAL SPOTS

ACCESS



- several entrances to be aware of
- multiple trails + road lead to site

TOPOGRAPHY



- NO 1.
- steep slope
 - right by Elias track

- NO 2.
- steep slope
 - next to most entrances



- NO. 3
- sloped, but less than other two
 - next to Elias Track



CONSIDERATIONS

- Potential spots does not have to be confined to one area
- Some spots may have seating where there is a lack thereof
 - Some spots may have a drinking fountain where there is a lack thereof
- Eg. the parking lookout may have a drinking fountain but no seat

EXPLORATION

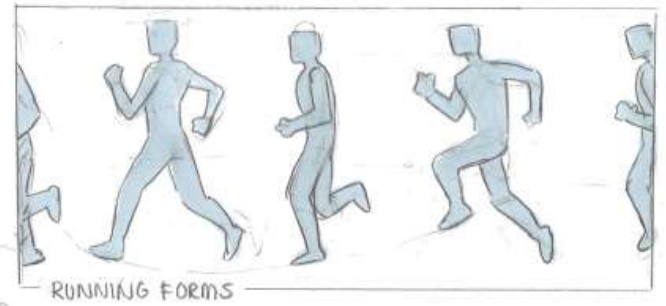
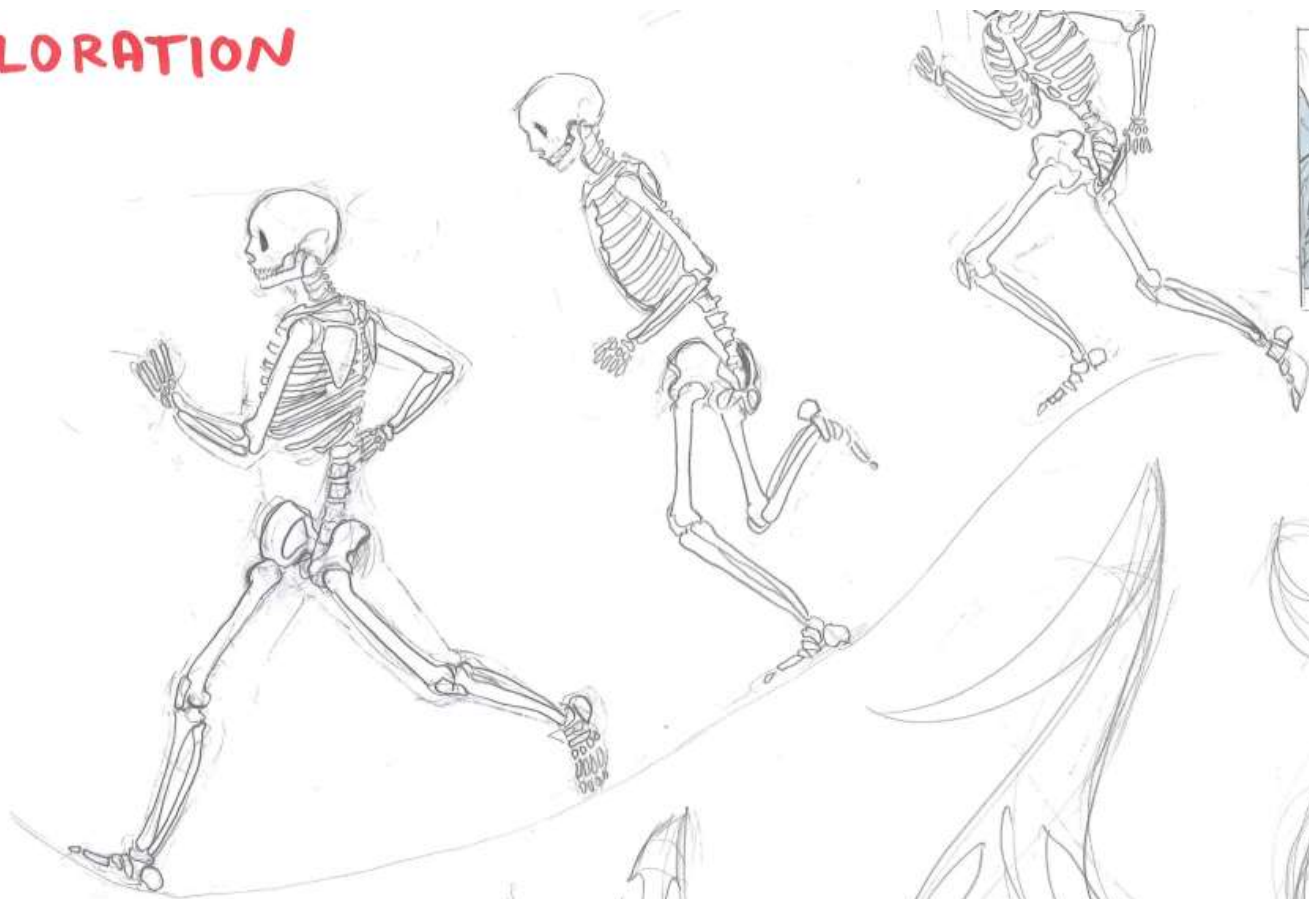

RUNNING FORMS

RU

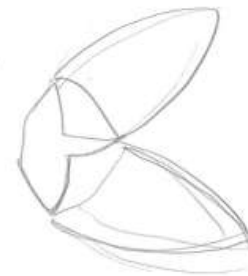

NOTE
FIX

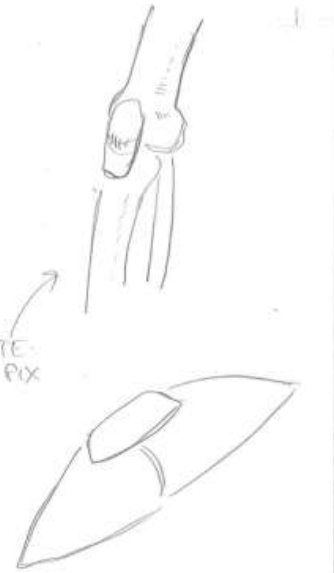

EXPLORATION



IDEATIONS

- SEAT -

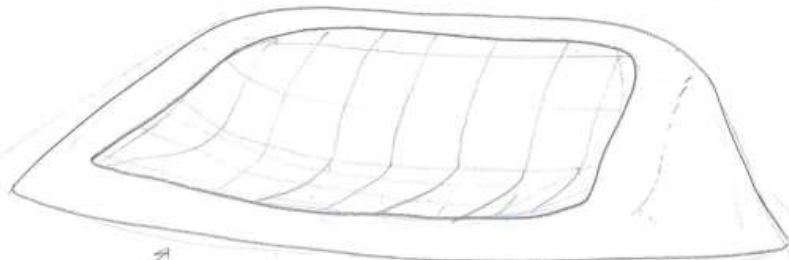
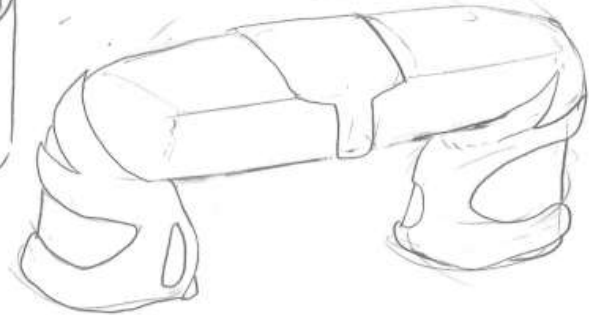
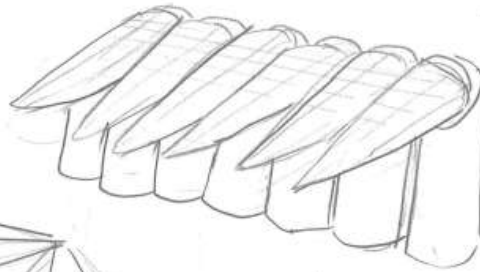
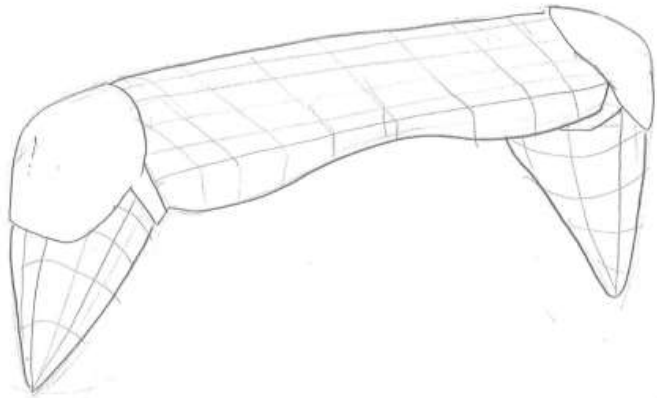

feels closed off,
like round pool

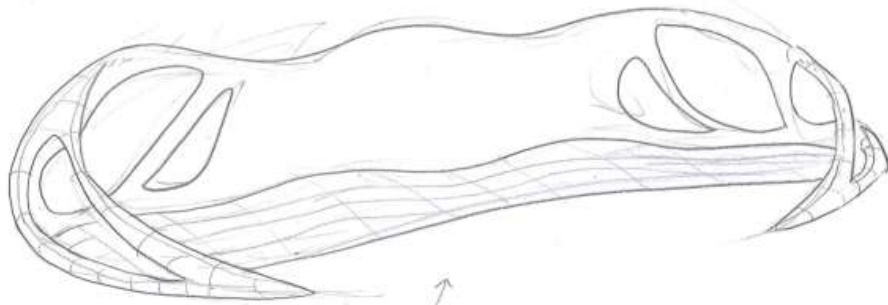
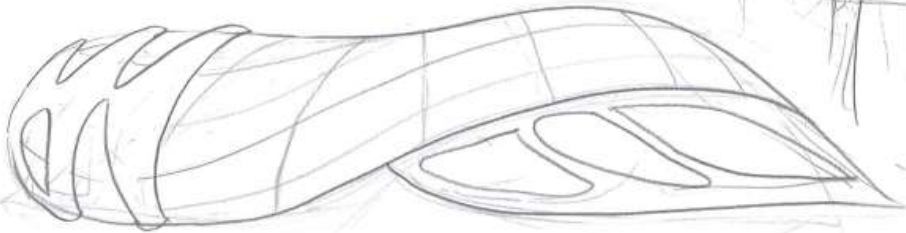

feels closed
off with arm
and back rest

designs have too much contrast

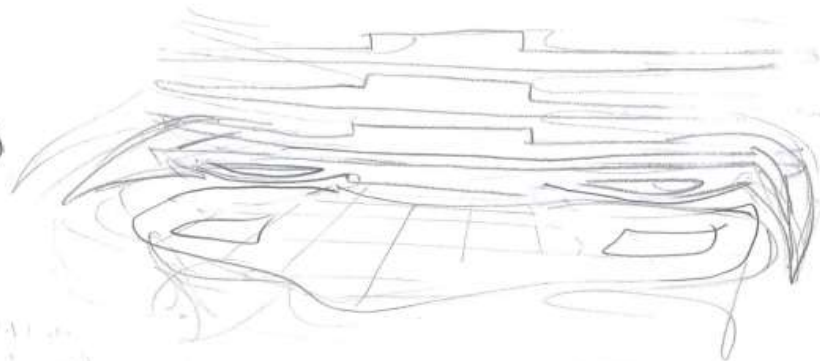

too obvious
in skeletal
aspects,
being

IDEATIONS

- SEAT -

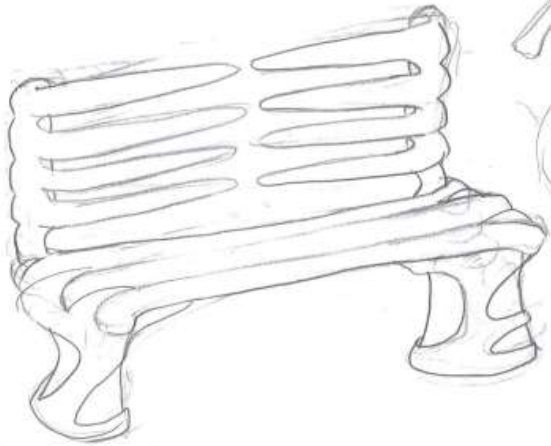

back rest feels less open → needs may be uncomfortable
↳ back rest may be uncomfortable

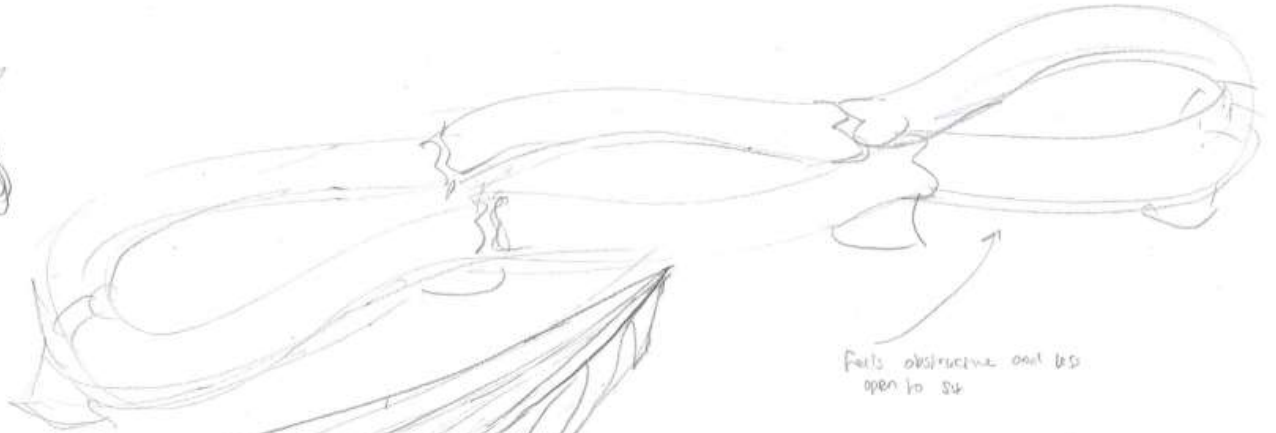

Feels obstructive and less open to sit



maybe a seating that follows the form of the landscape
↳ allow people have access to seats
↳ give a sculptural form i.e. landscape

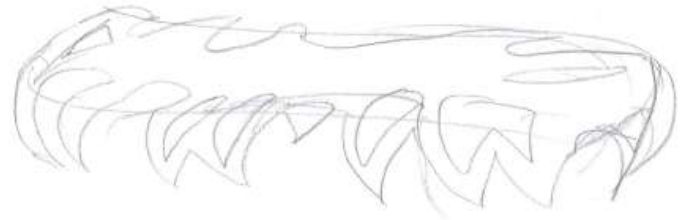
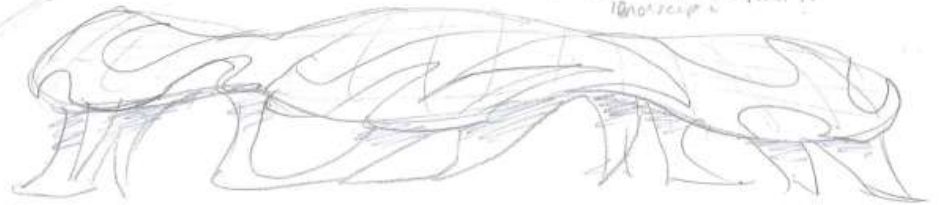

like the wrap around the bench design → ridges may be uncomfortable

IDEATIONS

- DRINKING FOUNTAIN -

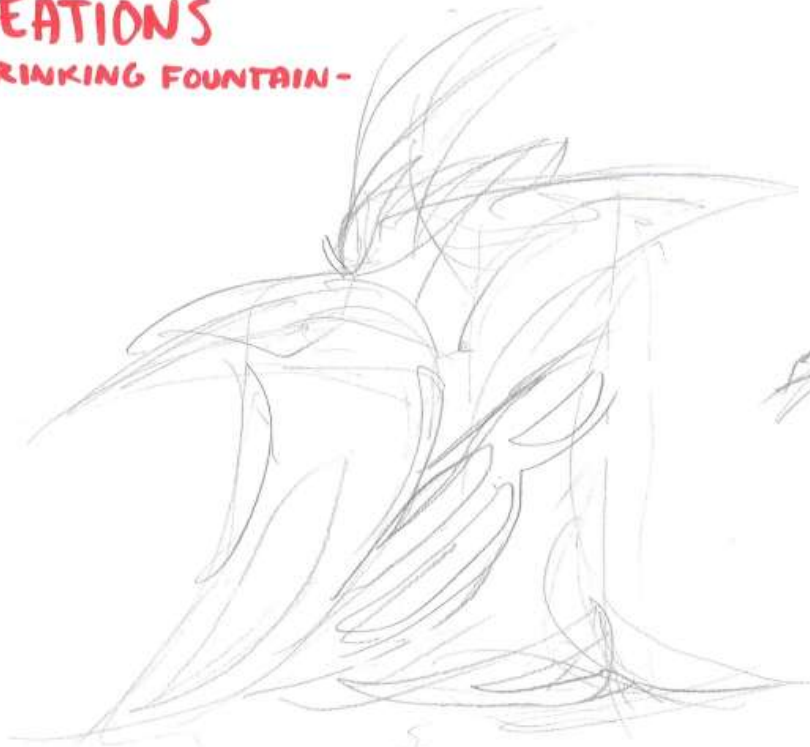

↳ Feels chunky
looks like a
tree stump,
could fit
site



↳ I like
the texture
and form,
feels less
obstructive



↳ I like how
simple this
is and the
wrapping / flow
effect



↳ this part
feels out of
place, too
much contrast

IDEATIONS

- DRINKING FOUNTAIN -



I like the
ribbing effect
↳ less edges
softer?

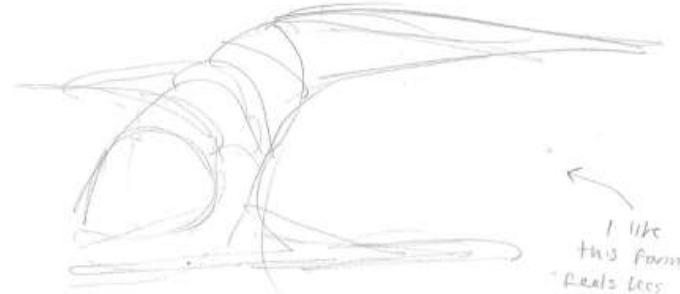

I like
this form,
feels less
chummy for
size

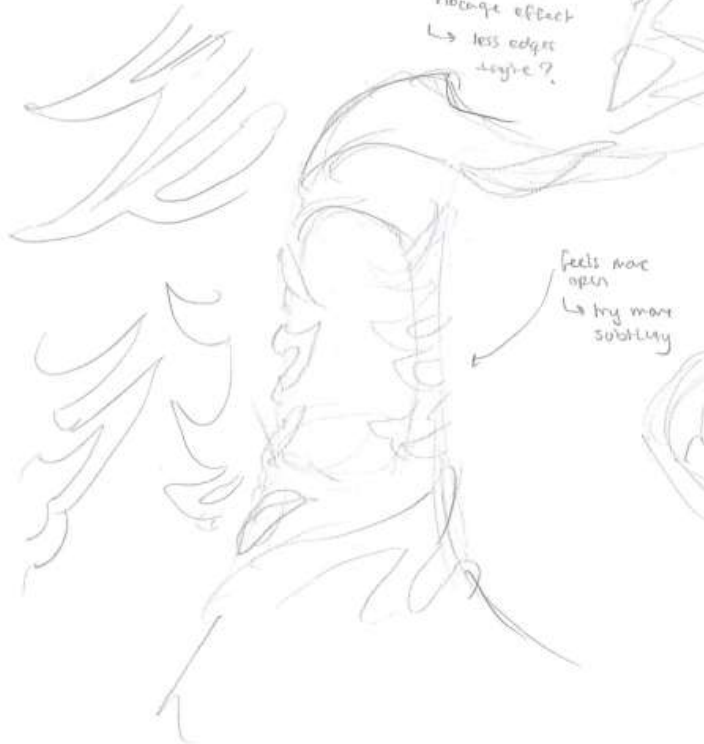

feels more
open
↳ try more
subtlety



very sharp
edges could
try rounded
design



edges are
uncomfortable
↳ rise of water
padding, bird
baths

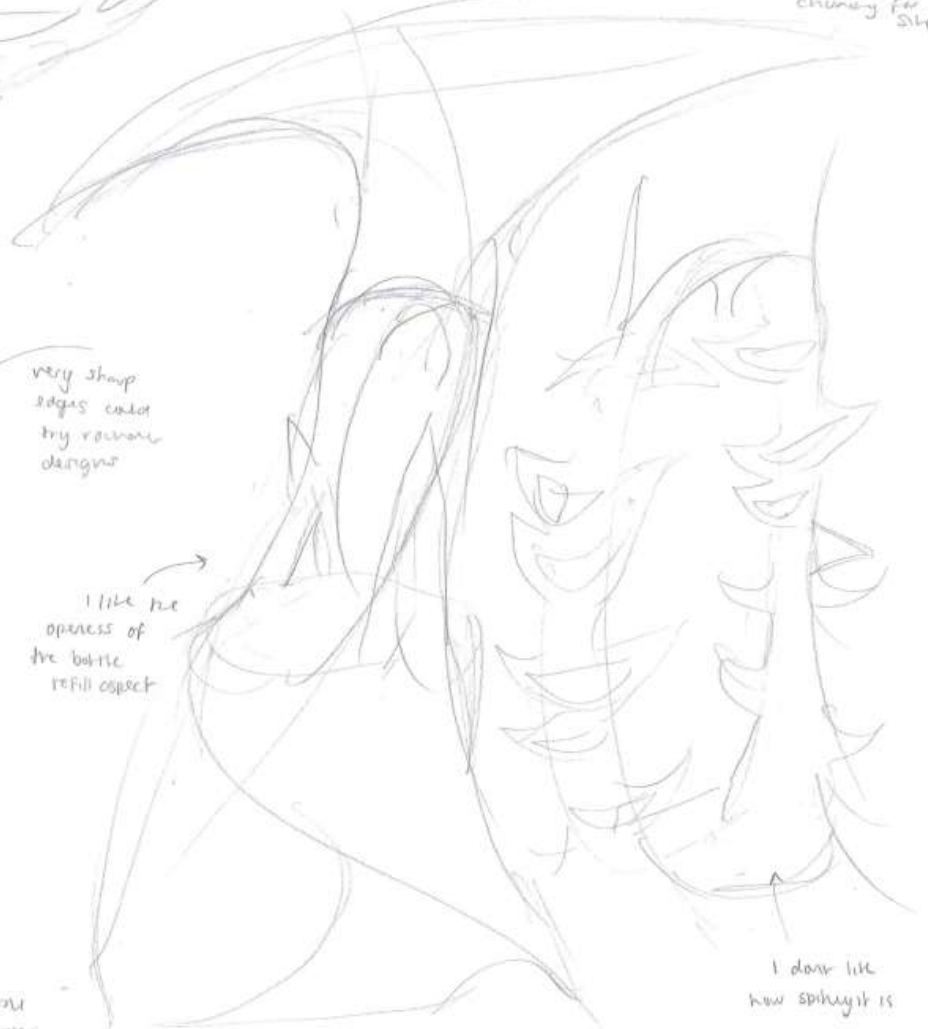

I like the
openness of
the bottle
refill aspect

I don't like
how spiky it is

IDEATIONS

- SEAT + DRINKING FOUNTAIN -

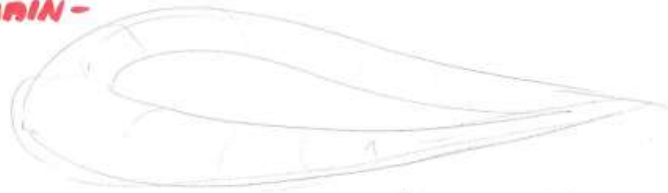

I like the form, doesn't look car friendly



I don't like how water fountain attaches to seat

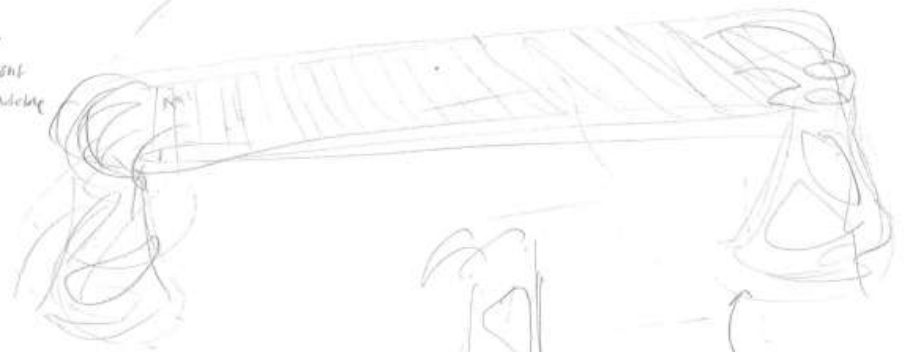

bench and bench legs feel like too much contrast too much, doesn't match

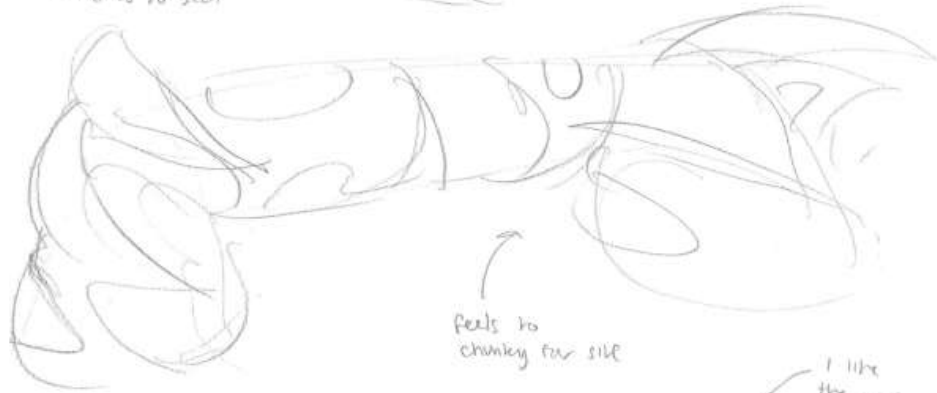

feels too chunky for size

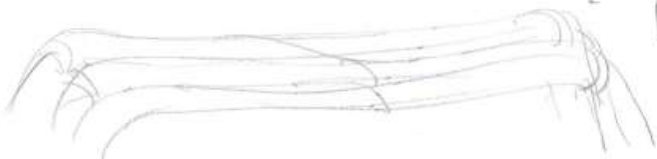

I like the []



feels chunky, don't like pole fountain with seat

CONCEPT

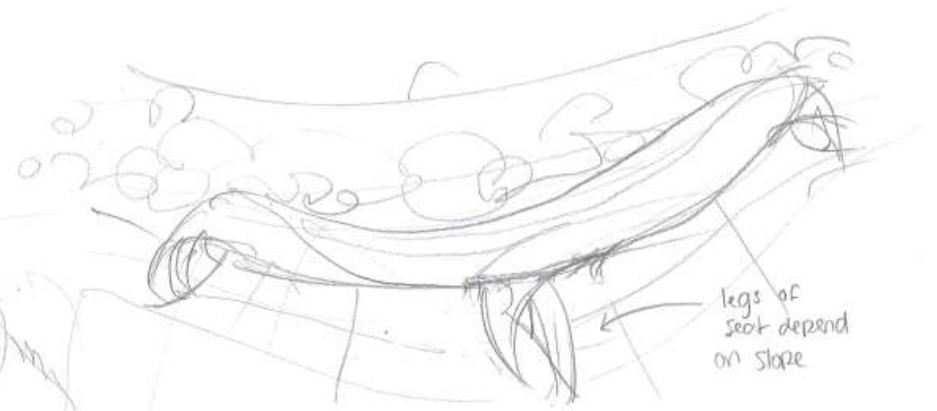

legs of seat depend on slope

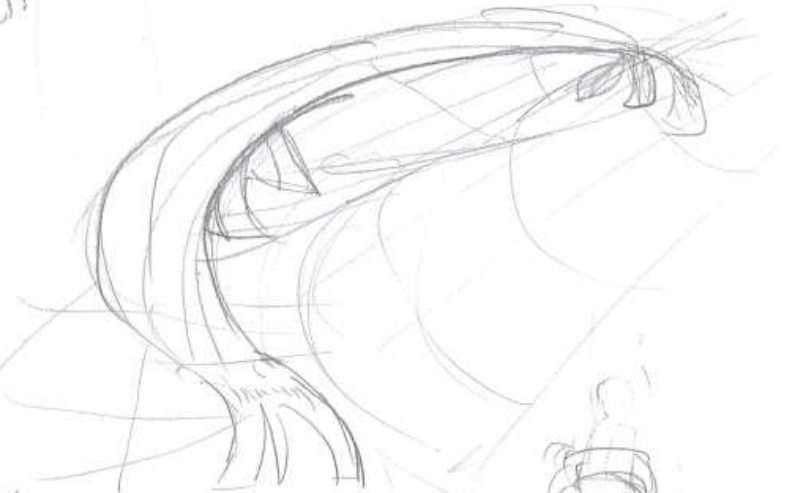

TOP VIEW

→ follows shape / flow of the land



→ don't like arm rests - breaks the 'flow' of the seat
→ cools

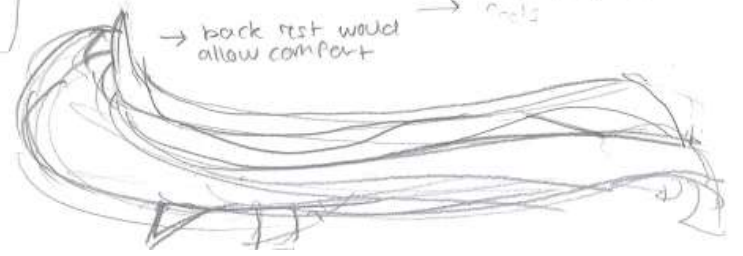

→ back rest would allow comfort

CONCEPT

→ I don't like
the straight lines
or rigidity

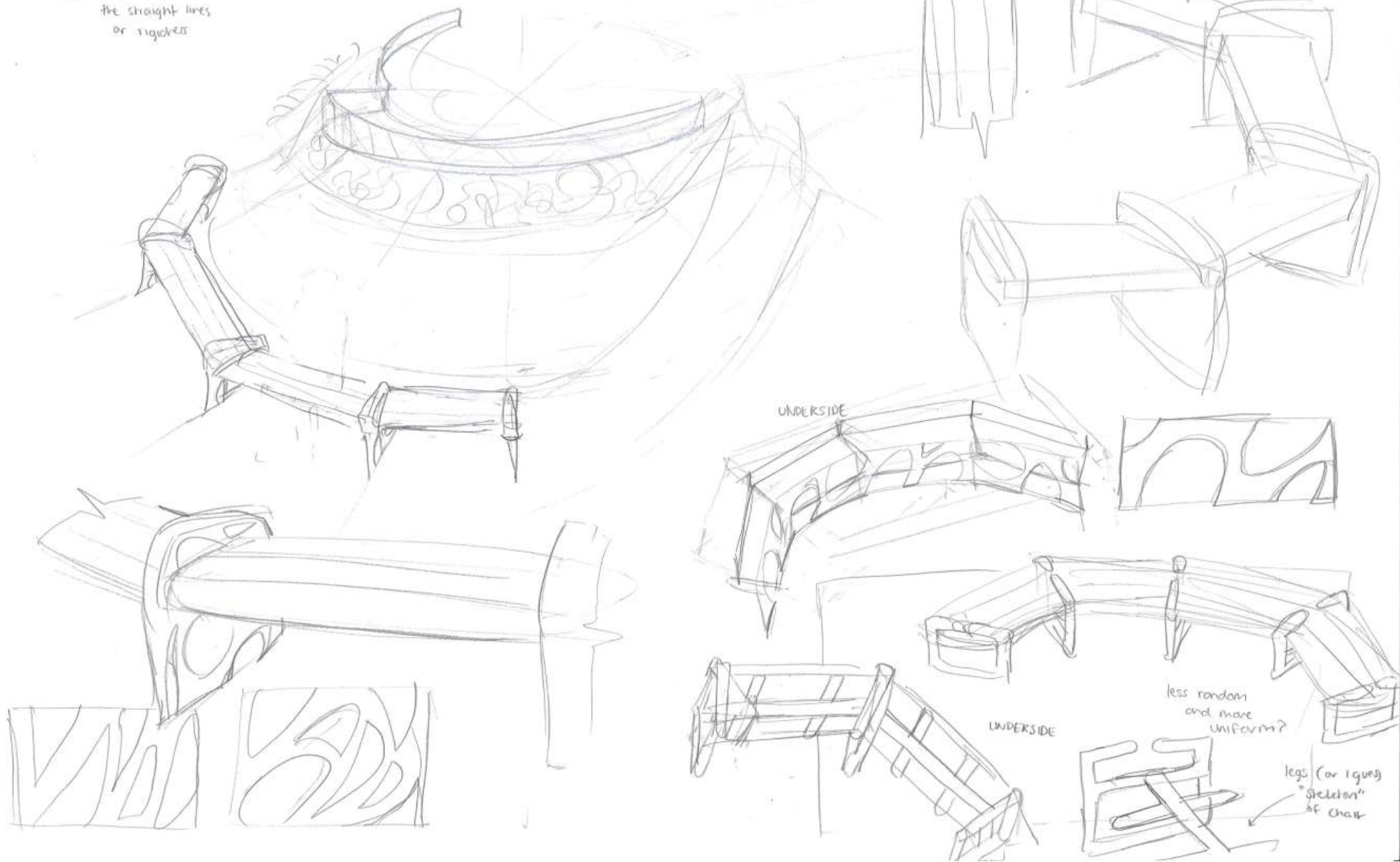

[CONCEPT DEVELOPMENT]

- REVISITING INSPIRATION -

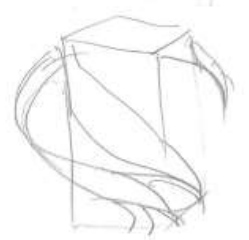
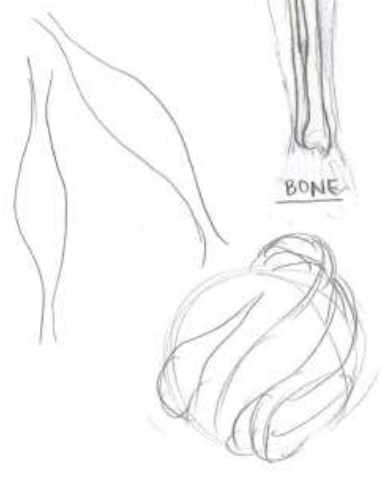
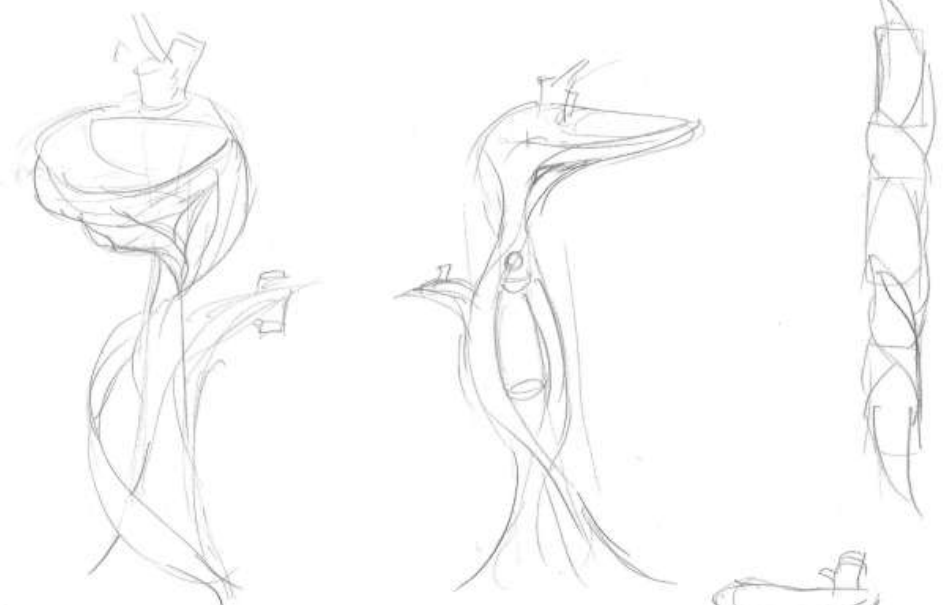
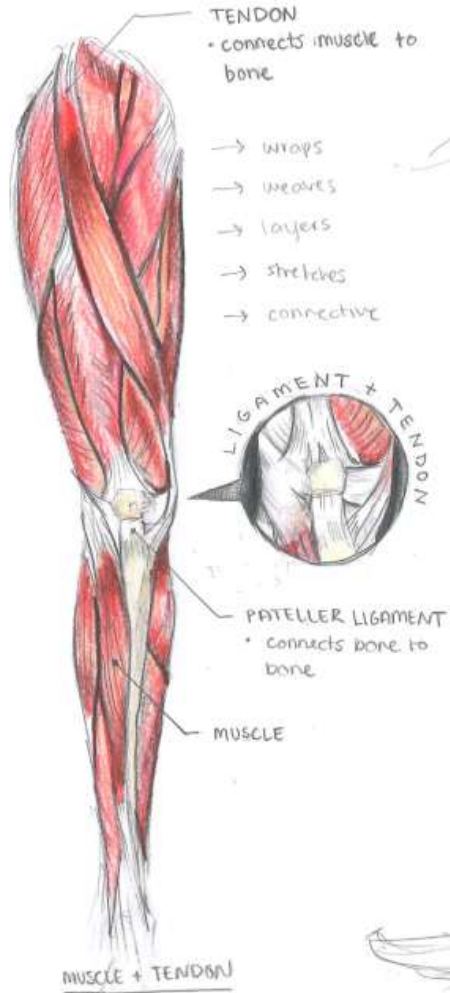

CONCEPT DEVELOPMENT

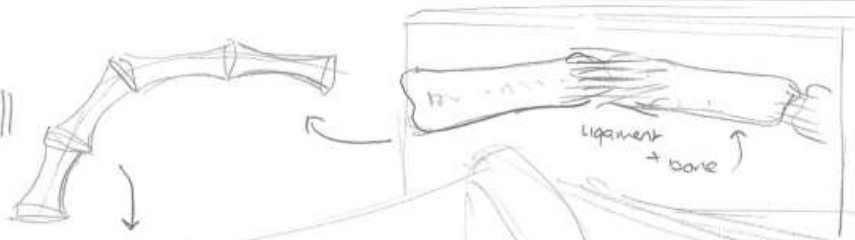

ligament + bone

I like this because it looks like a phalange

BENCH SEAT IDEAS

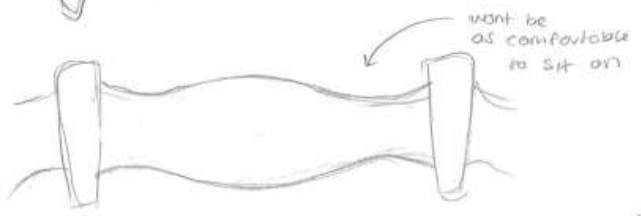

won't be as comfortable to sit on

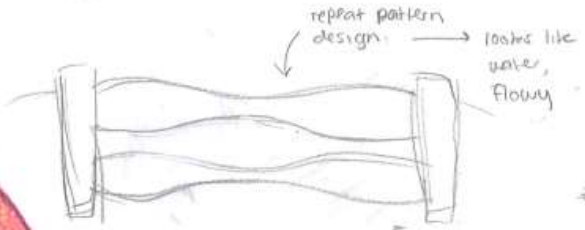

repeat pattern design → looks like water, flowy



cut at vaguely looks like a skeletal fore arm

muscles layering and layering over each other → like flowing water

curves

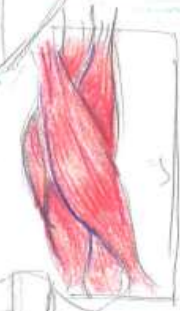
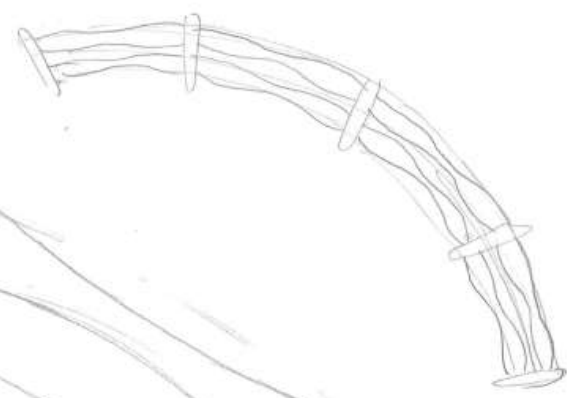

CONCEPT DEVELOPMENT

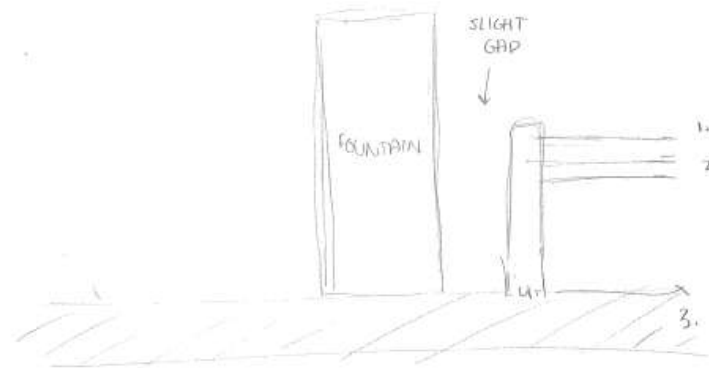

- POTENTIAL SPOTS FOR WATER TO RUN THROUGH
- 1. it can come through ground (3.)
 - 2. or seat (either 1. or 2.)
 - 3. or u. where it runs through seat into ground, then to fountain

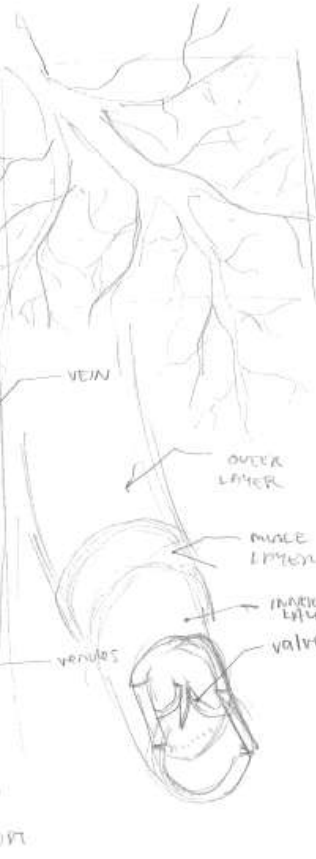
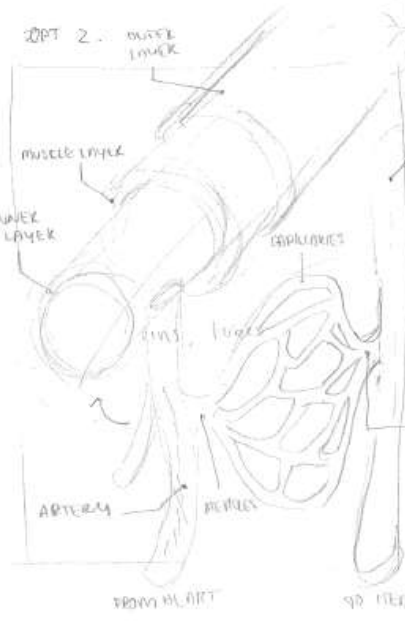

"brief info dump abt blood veins"

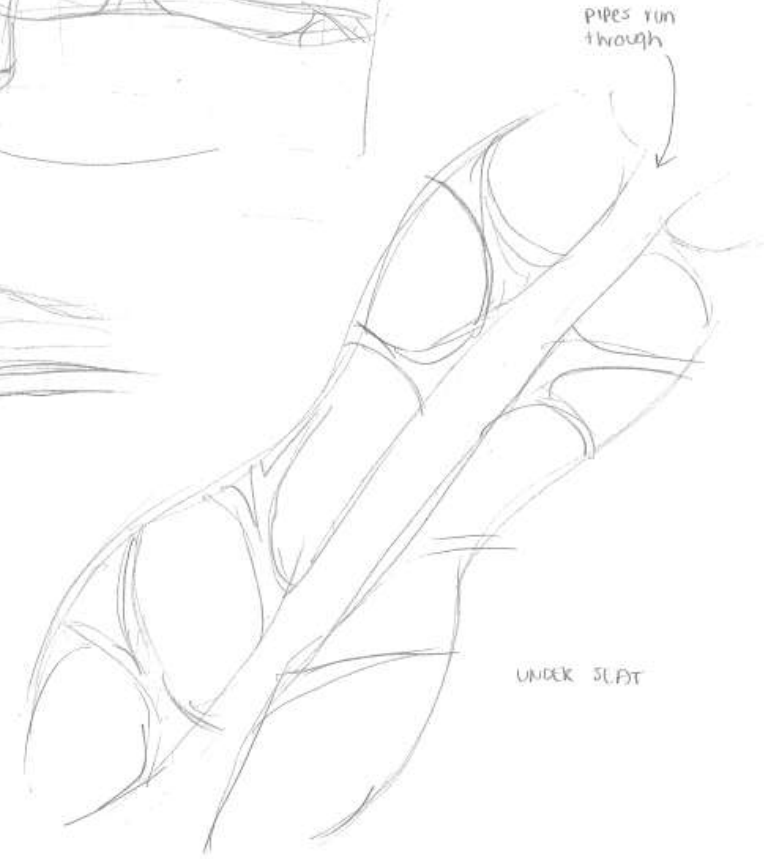
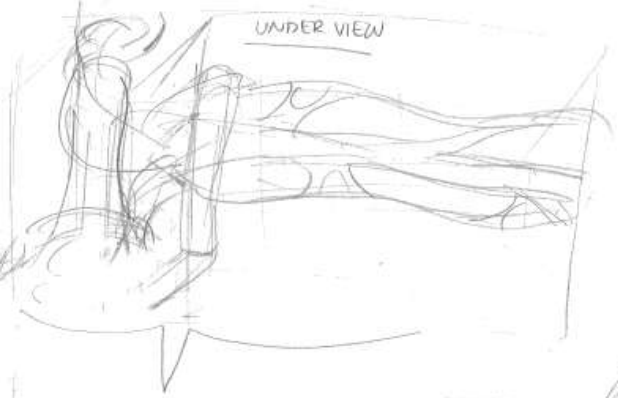
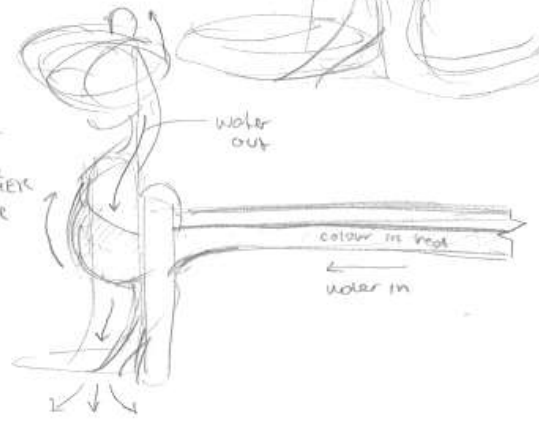

CONCEPT DEVELOPMENT

- PIPING SYSTEM -

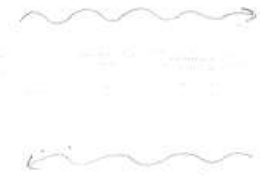
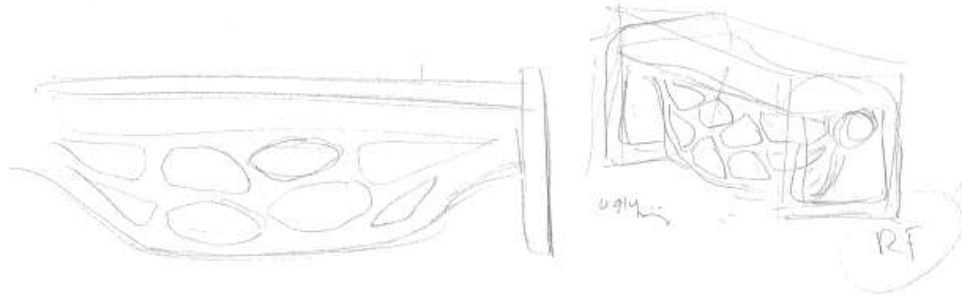
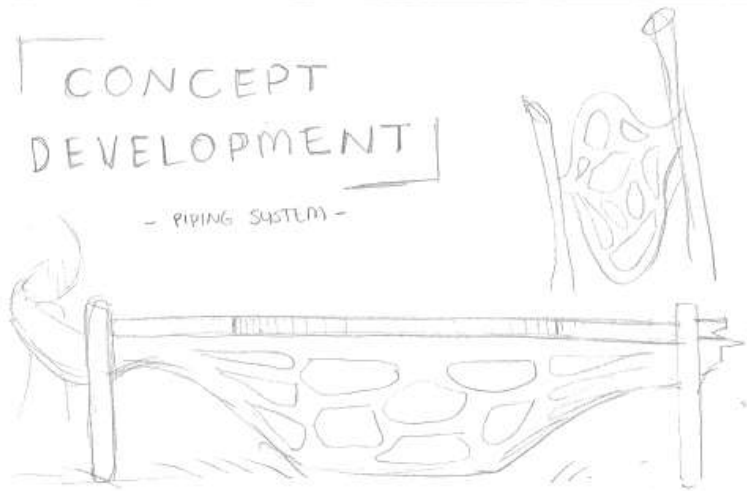

BOTTOMS OF SEAT

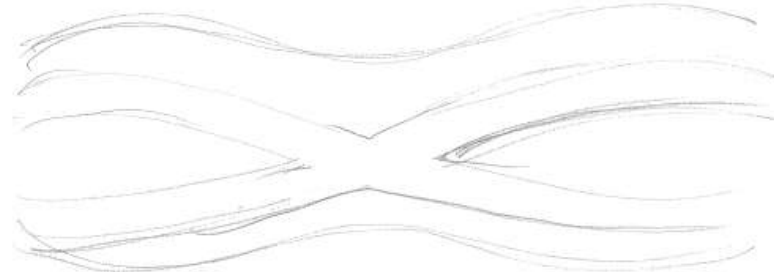
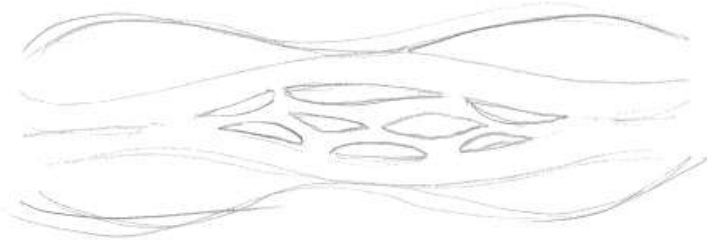
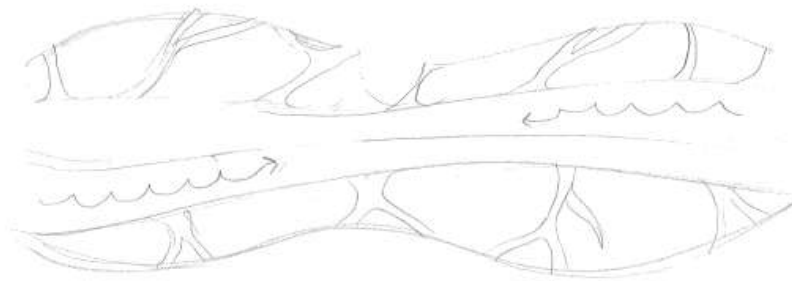
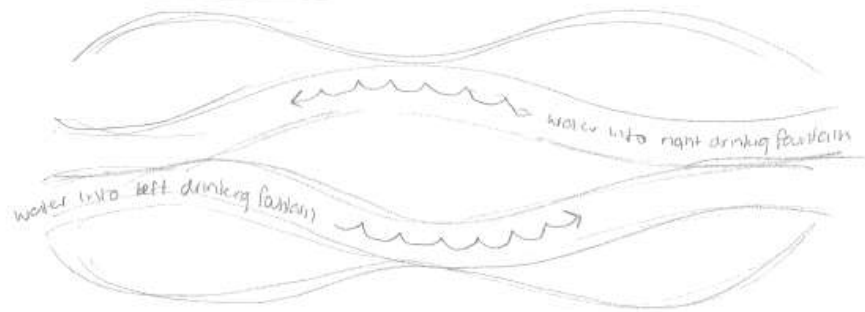

CONCEPT DEVELOPMENT - DRINKING FOUNTAIN DESIGN -

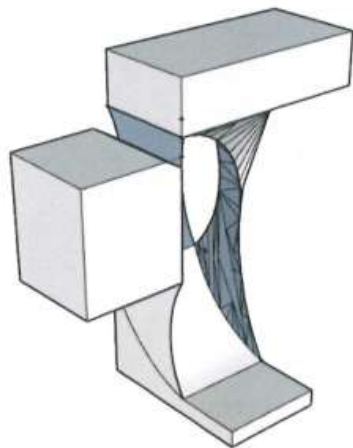
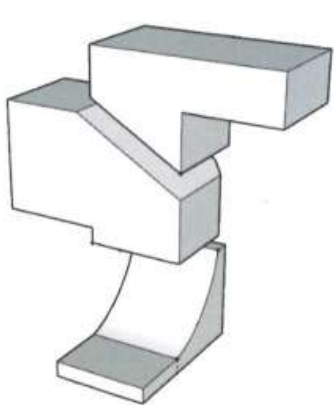
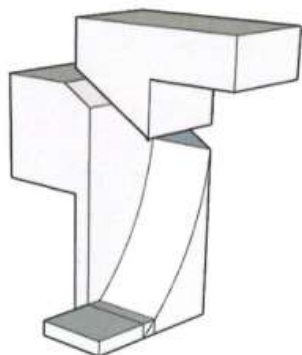
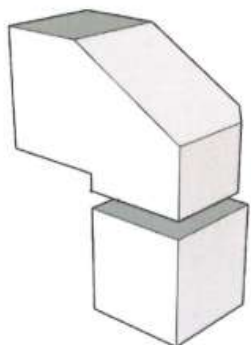

- twisting and folding like muscle
- connects basins like ligaments with bones
- bringing the curving. Flow effect with dog basin

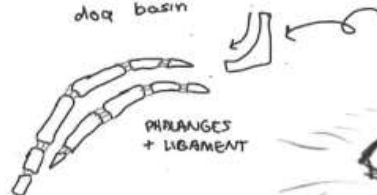

follow similar shape

bring cylindrical, rounder shapes with basin to resemble bone



DEVELOPMENT

- MEASUREMENTS + ERGONOMICS -
[mm]

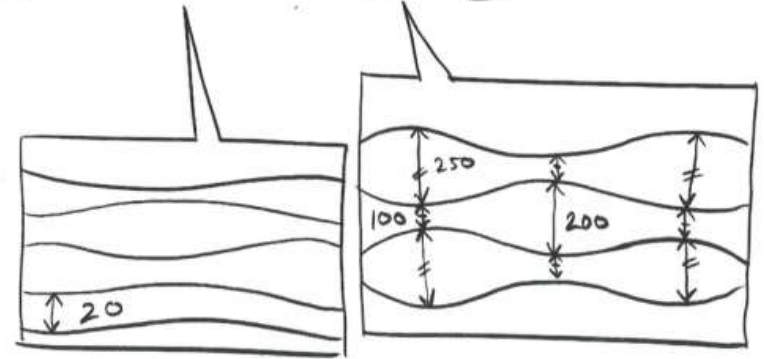
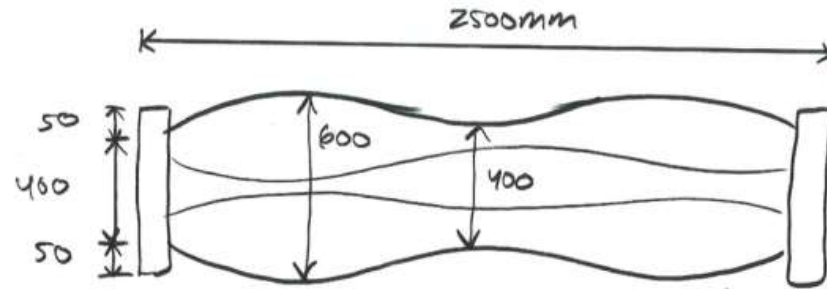
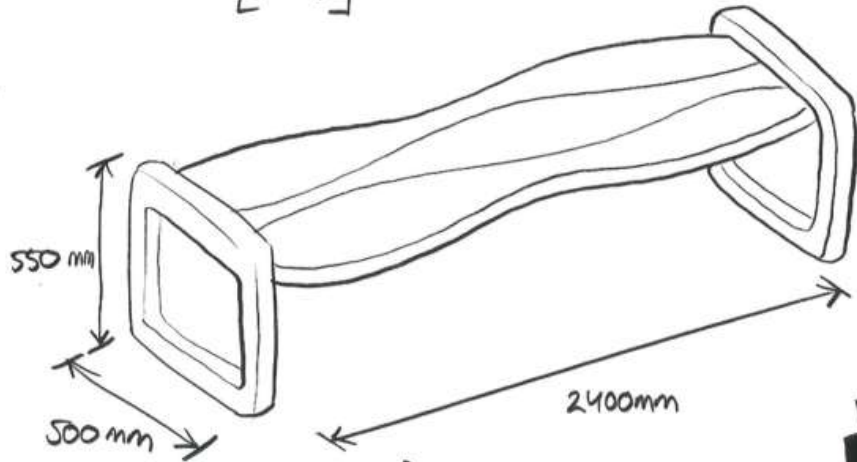

→ average space a person takes up is ~500 mm
↳ 2400 mm is able to comfortably fit 3 people with 300 mm gap between them

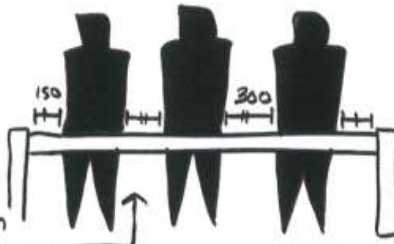

also leaves room for items such as bags

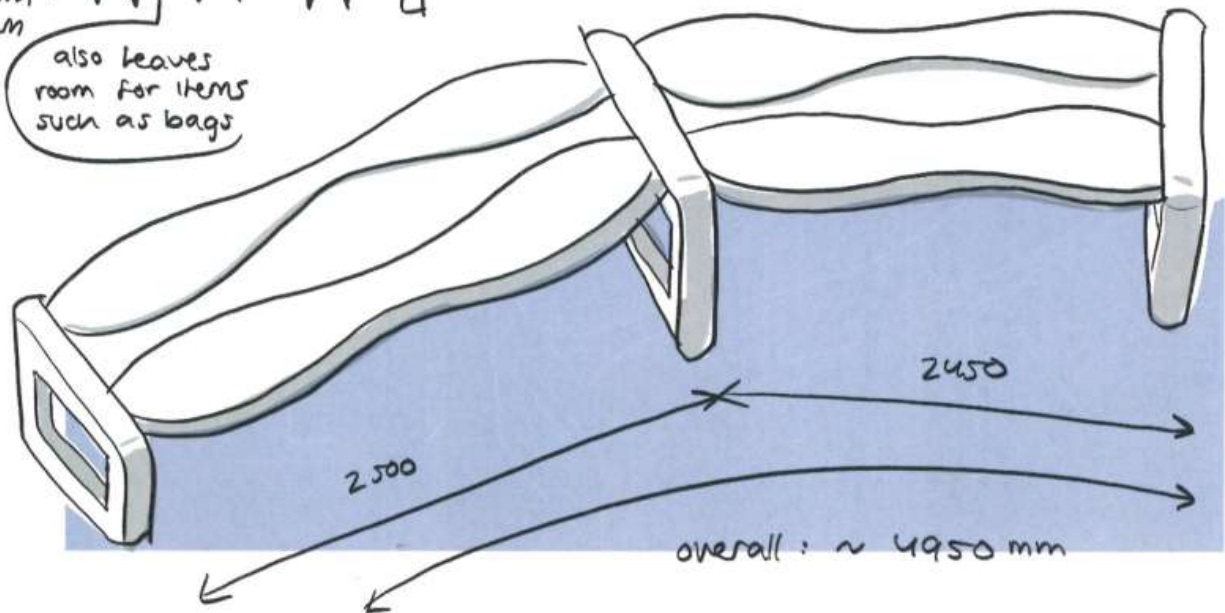
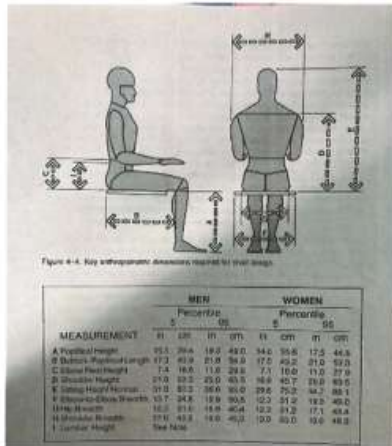
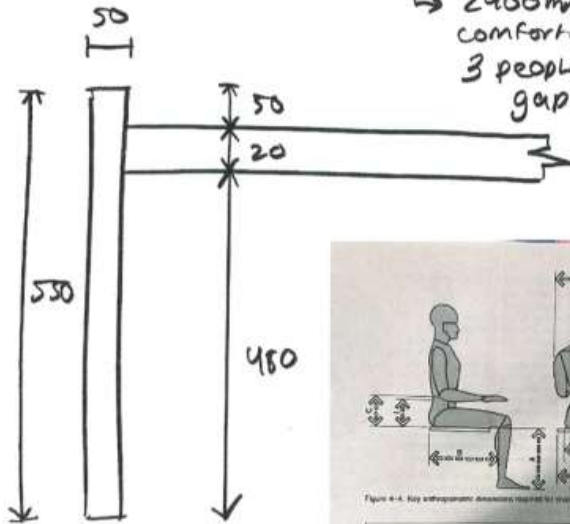

DEVELOPMENT - measurements - [mm]

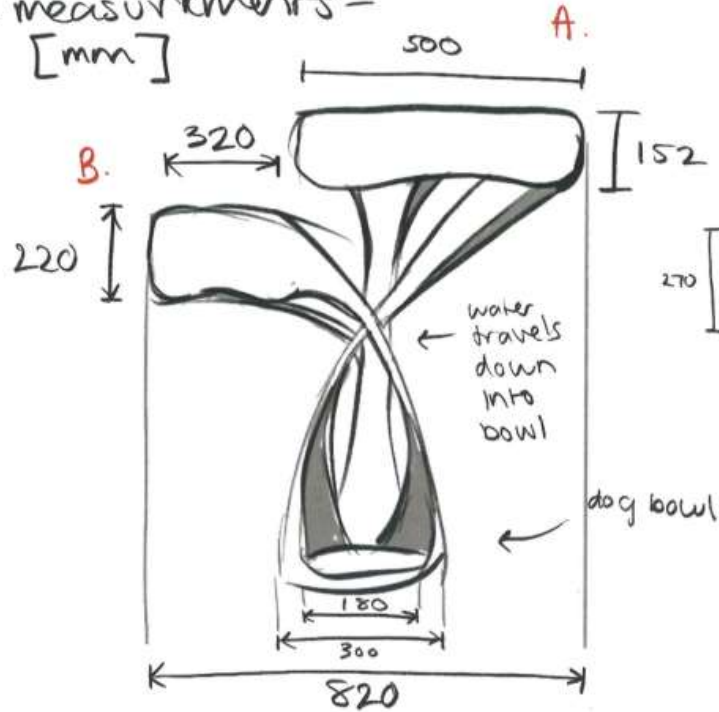

BASIN A.

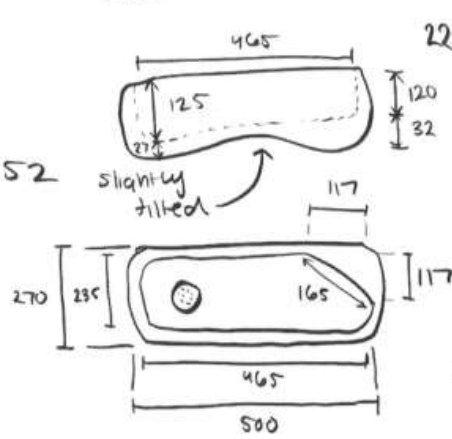

BASIN B.

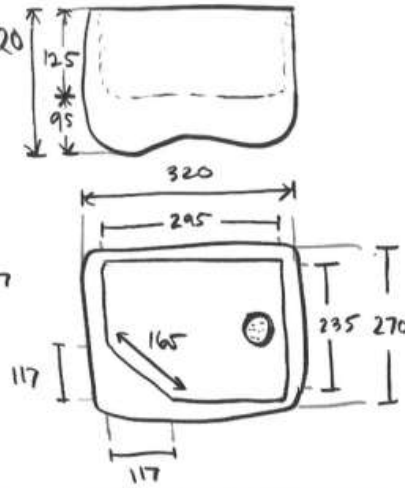

DOG BOWL

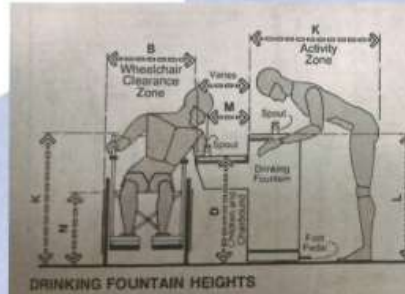
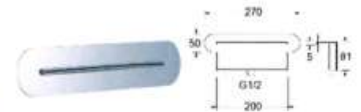
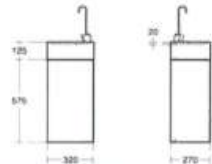
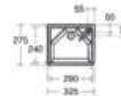
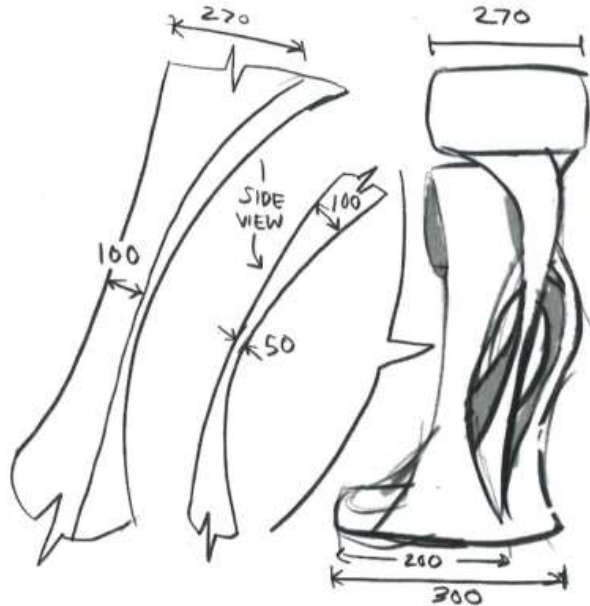
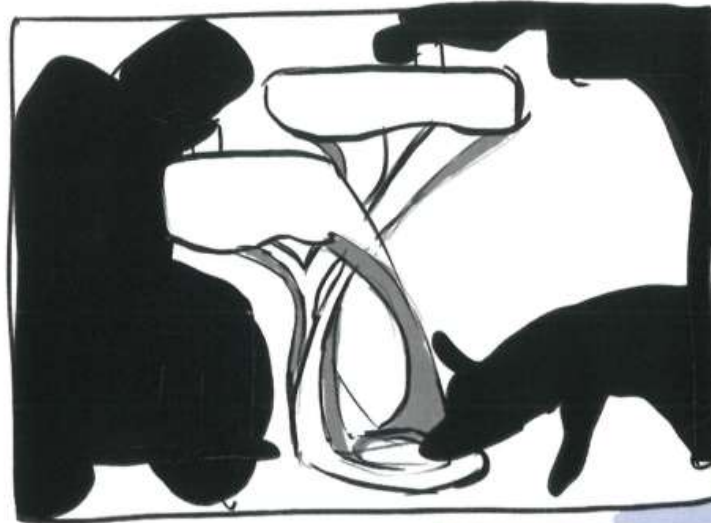
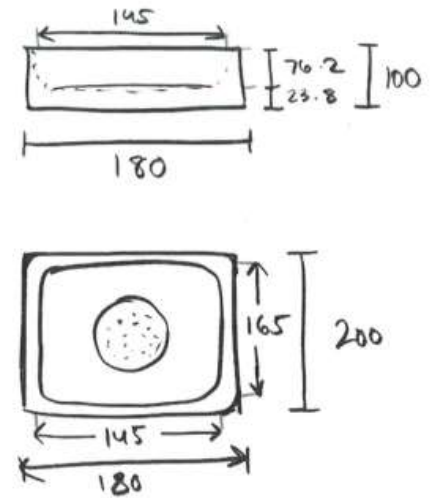

	in	cm
A	24	61.0
B	25	63.5
C	12	30.5
D	30	76.2
E	34	86.4
F	18	45.7
G	13-20	33.0-50.8
H	43	109.2
I	37	94.0
J	32.5	82.6
K	36	91.4
L	36 max	91.4 max
M	8 min	20.3 min
N	19	48.3

DRINKING FOUNTAIN HEIGHTS

Merit

Subject: Design and Visual Communication

Standard: 91627

Total score: M5

Marker commentary

The folio uses the starting point of the human skeleton to generate a range of forms with a collection of 3D sketches. Initial design ideas are more apparent when there is the use of figures to show scale and basic function for the Achievement criteria. Further exploration of the seat demonstrates the emerging train of thought, with the extending of the skeleton from the bones to tendons, and this is reinterpreted in further design ideas. A higher level of extension or transformation of the overall design forms is needed to reach a higher grade.