

No part of the candidate's evidence in this exemplar material may be presented in an external assessment for the purpose of gaining an NZQA qualification or award.



Mana Tohu Mātauranga o Aotearoa  
New Zealand Qualifications Authority

# Level 1 Design and Visual Communication 2025

**92003 Use instrumental drawing techniques to  
communicate own product or spatial design  
outcome**

## **EXEMPLAR**

**Achievement**

**TOTAL 03**

handle  
This is upwards  
because it  
is easier to  
pull down than out

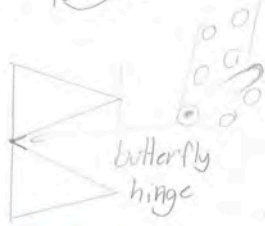
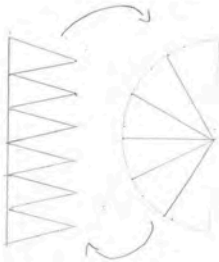

butterfly  
hinge

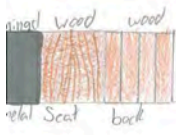

Colors &  
materials

metal Seat back

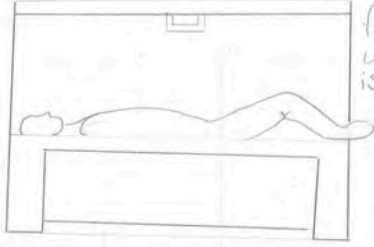

front view  
when the bench  
is closed

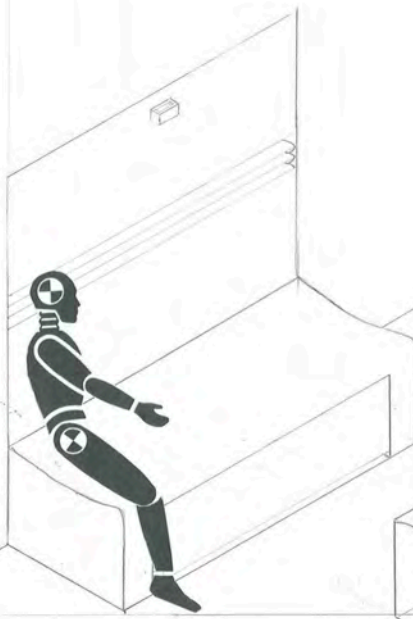

Pros  
It is big enough so  
that someone can lie on it  
but not too big as to  
take up too much space.  
The elbow lets it easily  
convert from a seat to a  
shelter. The handle makes  
it easy to pull down and  
push back up. The draw  
lets people safely store  
their belongings. It is  
very user friendly

Cons  
debris could get stuck in  
the elbow

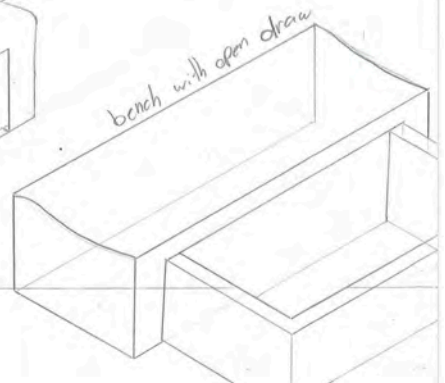

bench with open draw

Final Design

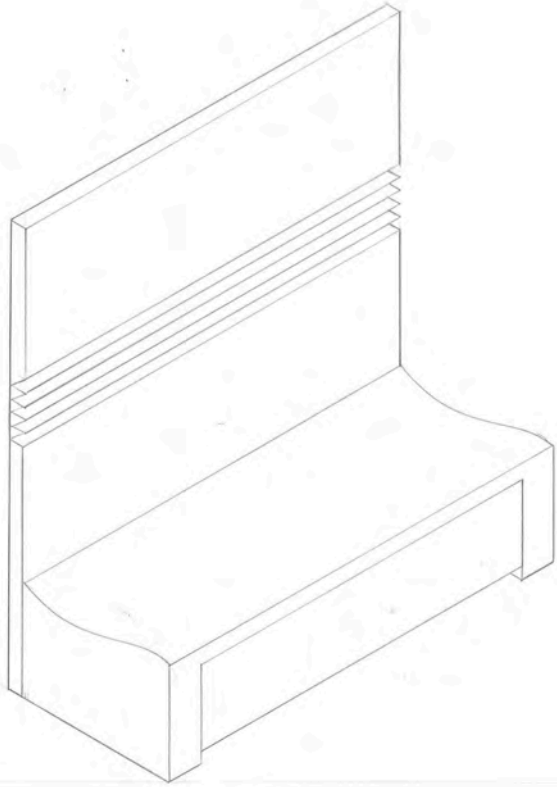

NOT to Scale

ISOMETRIC

31.5.25

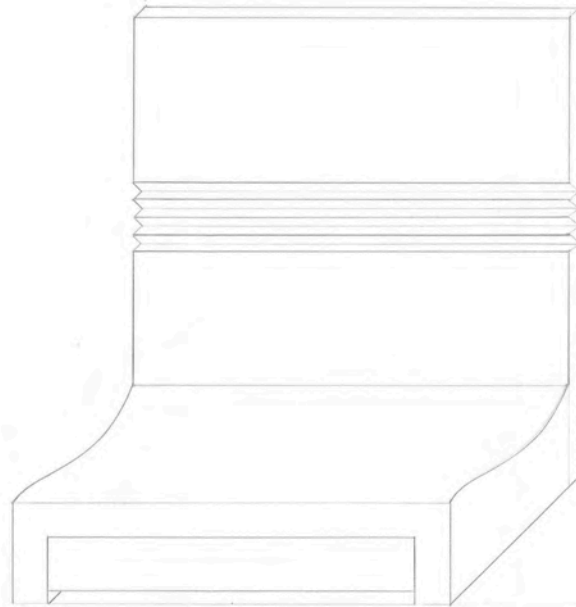

29.5.25

OBLIQUE

NTS

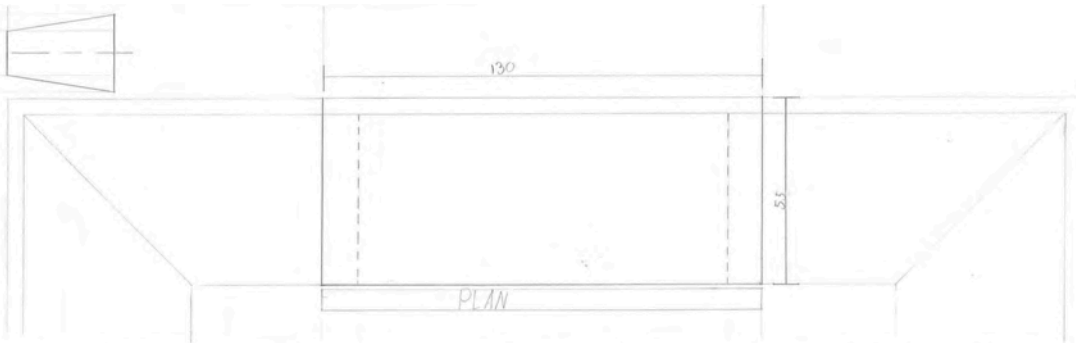
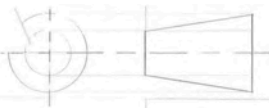

PLAN

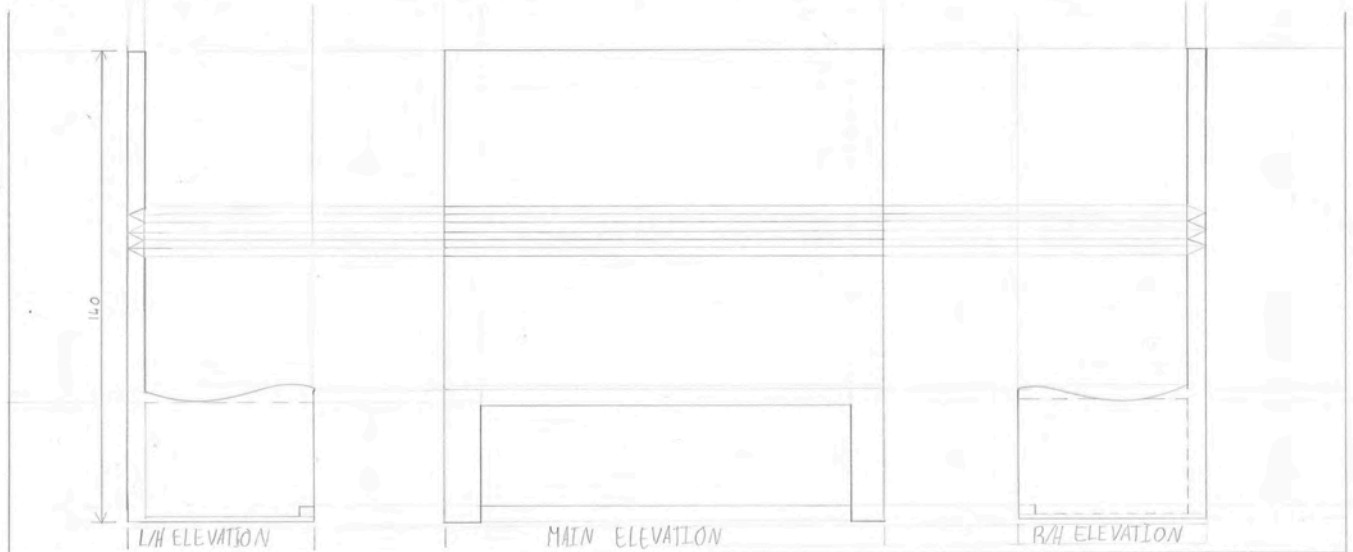

L/H ELEVATION

MAIN ELEVATION

R/H ELEVATION

1:10

ORTHOGRAPHIC

12.6.25

Need Rubber

## Achievement

**Subject:** Design and Visual Communication

**Standard:** 92003

**Total score:** 03

Marker commentary
<p>This submission is of a bench seat. The candidate completed the submission by hand and used accurate drawing techniques and symbols. Title block, scale, symbol, and labelling are all appropriate in this submission. The paraline drawing is correct, clear and relates to the orthographic. Further internal detail or construction could have assisted this submission to a higher grade.</p>